

SC230

OWNER'S

MANUAL

OWNER'S MANUAL

Precautions

Before you use this scanner, please read and observe the following.

IMPORTANT!

This scanning radio has been manufactured so that it will not tune to the radio frequencies assigned by the FCC for cellular telephone usage. The Electronic Communications Privacy Act of 1986, as amended, makes it a federal crime to intentionally intercept cellular or cordless telephone transmissions or to market this radio when altered to receive them. The installation, possession, or use of this scanning radio in a motor vehicle may be prohibited, regulated, or require a permit in certain states, cities, and/or local jurisdictions. Your local law enforcement officials should be able to provide you with information regarding the laws in your community.

Changes or modifications to this product not expressly approved by Uniden, or operation of this product in any way other than as detailed by this Operating Guide, could void your authority to operate this product.

EARPHONE WARNING!

Be sure to use only a monaural earphone with this scanner. You can also use an optional 32 Ω stereo headset. Use of an incorrect earphone or stereo headset might be potentially hazardous to your hearing. The output of the phone jack is monaural, but you will hear it in both headphones of a stereo headset.

Set the volume to a comfortable audio level coming from the speaker before plugging in the monaural earphone or a stereo headset of the proper impedance (32 Ω). Otherwise, you might experience some discomfort or possible hearing damage if the volume suddenly becomes too loud because of the volume control or squelch control setting. This might be particularly true of the type of earphone that is placed in the ear canal.

WARNING!

Uniden **does not** represent this unit to be waterproof. To reduce the risk of fire or electrical shock, **do not** expose this unit to rain or moisture.

Motorola®, *PL®*, *Private Line®*, *DPL®*, and *Digital Private Line®* are registered trademarks of Motorola, Inc.

NASCAR® is a registered trademark of the National Association for Stock Car Auto Racing, Inc.

Uniden® and *Bearcat®* are registered trademarks of Uniden America Corporation.

Close Call™ is a proprietary trademarks of Uniden America Corporation.

Other trademarks used throughout this manual are the property of their respective holders.

Contents

The FCC Wants You to Know	7
Scanning Legally	7
Introduction	9
Feature Highlights	11
About This Manual.....	14
How the Scanner's Controls Are Represented in This Manual ...	15
Entering Text	15
Understanding Scanning	16
Understanding the Scanner's Memory	16
What is Scanning?.....	16
What is Searching?	16
What is CTCSS/DCS?.....	17
Using the Scanner at the Racetrack.....	19
Conventional Scanning.....	19
Where To Get More Information.....	20
Included With Your Scanner	22
Setting Up Your Scanner	23
Using Internal Batteries	23
Using Rechargeable Batteries.....	25
Using AC Power	26
Connecting the Antenna	26
Connecting an Earphone/Headphone	27
Connecting an Extension Speaker	27
Attaching the Belt Clip	27
Attaching the Wrist Strap.....	28
Installing the Demo Software.....	28
A Look At The Keypad.....	29
A Look At The Display	32
Using Menu	33
Using Func	33
Using the Scroll Control.....	33
Basic Operation	34
Turning On the Scanner and Setting the Squelch	34
Scanning Systems.....	34
Scanning Preprogrammed Races	35
Before You Get To The Track	35
When You Get To The Track.....	35
Selecting Systems to Scan.....	36
Selecting System Channel Groups.....	37
Locking/Unlocking Systems.....	37
Locking/Unlocking Channels	37
Temporarily Holding On a System.....	38
Holding On a Channel	38
Quick-Storing Channels.....	38
Quickly Recalling Channels.....	39
Other Settings	40
Displaying System Information	40
Viewing Memory Used	40
Viewing the Firmware Version	40

Contents

Adjusting the Key Beep	40
Locking/Unlocking the Keypad	40
Turning Power Save On or Off	40
Priority Scan	40
Using the Backlight	41
Initializing the Scanner's Memory	41
Using the PC Control and Cloning Options	42
Connecting Your Scanner to a Personal Computer	42
Cloning the Scanner	43
Using the Menu	44
Programming Radio Systems	46
Quickly Programming Racing Systems	47
Manually Programming Racing Systems	49
Editing the Car	49
Entering/Editing a Car Number	50
Editing a Driver	50
Setting a Car's Quick Key	51
Editing a Car's Channel	51
Deleting a Car	51
Setting Lockout On A Car	52
Programming Conventional Systems.....	52
Entering/Editing Conventional Channel Groups	53
Entering/Editing Conventional Channels	53
Programming/Editing Optional Settings.....	55
System-Level Settings	55
Editing the System Name	55
Editing the System Quick Key (Conventional Systems Only)	55
Setting System Lockout	56
Setting the System Hold Time	56
Setting the Channel Delay Time	57
Setting Data Skip	57
Deleting Systems	58
Copying Systems.....	58
Group-Level Settings	58
Entering/Editing the Group Name.....	58
Setting the Group Quick Key	59
Setting Group Lockout	60
Deleting Groups.....	60
Channel-Level Settings.....	60
Editing the Channel Name (Conventional Systems Only)	60
Setting Channel Priority	61
Setting Channel Alert	62
Setting CTCSS/DCS	62
Setting Channel Modulation	63
Setting Channel Attenuation	64
Setting the Frequency Step	64
Setting Channel Lockout	65
Deleting Channels	65
Copying/Pasting Channels	66

Contents

Searching and Storing	67
Service Search	67
Quick Search	68
CTCSS/DCS Search	68
Custom Search	68
Editing a Custom Search Range	69
Auto Search and Store	70
Selecting a System	70
Storing a System	71
Using the Close Call Feature	72
Setting Close Call Options	73
Close Call Hits	74
Search and Close Call Options	75
Managing Locked-Out Frequencies	75
Unlocking All Frequencies	75
Reviewing Locked Out Frequencies	75
Searching for Subaudible Tones	75
Screening Out Paging Systems	76
Finding Repeater Output Frequencies	76
Setting the Maximum Auto Store Value	77
Setting the Modulation Type	77
Setting Attenuation	78
Setting Data Skip	78
Setting the Delay Time	78
Setting the Search Frequency Step	79
Using Weather Alert (SAME)	80
Searching For a Weather Broadcast	80
Turning Weather Alert On/Off	80
Programming a SAME Group	81
Setting WX Alert Priority	82
Care and Maintenance	83
Troubleshooting	85
Specifications	87
Optional Accessories	89
Planning	90
Collecting Information	90
Filling Out The Racing System Worksheet	92
Race Name	92
Car #/Driver-Frequency-Priority-CTCSS/DCS	92
Racing System Worksheet	93
Filling Out The Conventional System Worksheet	94
System Name and Quick Key	94
Group Name and Quick Key	94
Frequency-Alpha Tag-Priority-CTCSS/DCS	94
Conventional System Worksheet	95
Preprogrammed Systems	96
One-Year Limited Warranty	97

Contents

The FCC Wants You to Know

This scanner has been tested and found to comply with the limits for a scanning receiver, pursuant to Part 15 of the *FCC Rules*. These limits are designed to provide reasonable protection against harmful interference in a residential installation. This scanner generates, uses, and can radiate radio frequency energy and, if not installed and used in accordance with the instructions, may cause harmful interference to radio communications.

However, there is no guarantee that interference will not occur in a particular installation. If this scanner does cause harmful interference to radio or television reception, which can be determined by turning the scanner on and off, you are encouraged to try to correct the interference by one or more of the following measures:

- Reorient or relocate the receiving antenna
- Increase the separation between the scanner and the receiver

This device complies with Part 15 of the *FCC Rules*. Operation is subject to the following two conditions:
1) This device may not cause harmful interference, and
2) this device must accept any interference received, including interference that may cause undesired operation.

Scanning Legally

Your scanner covers frequencies used by many different groups, including police and fire departments, ambulance services, government agencies, private companies, amateur radio services, military operations, pager services, and wireline (telephone and telegraph) service providers. It is legal to listen to almost every transmission your scanner can receive. However, there are some transmissions that you should never intentionally listen to. These include:

- Telephone conversations (cellular, cordless, or other private means of telephone signal transmission)
- Pager transmissions
- Any scrambled or encrypted transmissions

The FCC Wants You to Know

According to the Electronic Communications Privacy Act (ECPA), you are subject to fines and possible imprisonment for intentionally listening to, using, or divulging the contents of such a conversation unless you have the consent of a party to the conversation (unless such activity is otherwise illegal). This scanner has been designed to prevent the reception of cellular telephone transmissions and the decoding of scrambled transmissions. This is done to comply with the legal requirement that scanners be manufactured so they are not easy to modify to pick up these transmissions. Do not open your scanner's case to make any modifications that could allow it to pick up transmissions that are illegal to monitor. Modifying or tampering with your scanner's internal components or using it in a way other than as described in this manual could invalidate your warranty and void your FCC authorization to operate it.

In some areas, mobile use of this scanner is unlawful or requires a permit. Check the laws in your area. It is also illegal in many areas (and a bad idea everywhere) to interfere with the duties of public safety officials by traveling to the scene of an incident without authorization.

Introduction

Your SC230 scanner is a state-of-the-art scanner radio with automatic scanning capabilities. You can store frequencies such as racing, police, fire/emergency, marine, air, and other communications into the scanner. You can carry it with you wherever you go, use it at home as a base unit, or install it in your vehicle as a mobile unit.

You can use the scanner's scroll control to quickly select channels and frequencies, and you can automatically program channels in a system using the AutoStore feature.

Use your scanner to monitor:

- Automobile races
- Public safety systems
- Police and fire departments (including rescue and paramedics)
- NOAA weather transmissions
- Business/Industrial radio
- Utilities
- Marine and amateur (ham radio) bands
- Air band
- Railroad

This table lists the frequency ranges, default frequency step, default mode (AM or Narrowband FM), and type of transmissions you can hear for each range.

Frequency Range (MHz)	Step (kHz)	Mode	Transmission
25.0-26.960	5	AM	Petroleum/ Broadcast Band
26.965- 27.405	5	AM	Citizens Band Class D
27.410- 27.995	5	AM	Business Band
28.0-29.680	20	NFM	10 Meter Amateur Band

Frequency Range (MHz)	Step (kHz)	Mode	Transmission
29.7-49.990	10	NFM	VHF Low Band
50.0-54.0	20	NFM	6 Meter Amateur Band
108.0-136.9750	25	AM	Aircraft Band
137.0-143.9875	12.5	NFM	Military Band
144.0-147.995	5	NFM	2 Meter Amateur Band
148.0-150.7875	12.5	NFM	Military Band
150.800-161.995	5	NFM	VHF High Band
162.0-174.0	12.5	NFM	Federal Government
216.0-224.9800	20	NFM	1.25 Meter Amateur Band
400.0-405.9875	12.5	NFM	Miscellaneous
406.0-419.9875	12.5	NFM	Federal Land Mobile
420.0-449.9875	12.5	NFM	70 cm Amateur Band
450.0-469.9875	12.5	NFM	UHF Standard Band
470.0-512.0	12.5	NFM	UHF TV Band
806.0-823.9875	12.5	NFM	Public Service Band
849.0125-868.9875	12.5	NFM	Public Service Band
894.0125-956.0000	12.5	NFM	Public Service Band
1240.0000-1300.0000	25	NFM	25 cm Amateur Band

Introduction

Feature Highlights

General

Close Call™ RF Capture Technology - you can set the scanner so it detects and provides information about nearby radio transmissions. See “Using the Close Call Feature” on Page 72 for more information.

Dynamically Allocated Channel Memory - your scanner’s memory is organized so that it more closely matches how radio systems actually work, making it easier to program and use your scanner and determine how much memory you have used and how much you have left.

Preprogrammed Races - your scanner is preprogrammed with NASCAR Nextel, Busch, Craftsman, Indy, ARCA, and Champ series races.

Quick Race Programming – lets you quickly and easily enter information about a specific race.

Quick Keys – You can set the scanner so you can select a race or systems and groups by pressing a single key. This makes it easy to listen to or quickly lock out those systems or groups you don’t want to scan.

Quick Car Select – You can set the scanner so you can select and listen to a car by pressing a single key.

Pager Screen – You can set the scanner so it ignores hits generated by common pager frequencies while using the Close Call or search features.

Ten Service Searches - frequencies are preset in separate public safety, news, amateur radio, marine, railroad, air, CB radio, FRS/GMRS, racing, and special searches, to make it easy to find specific transmissions.

Lockout – You can lock out any system, group, frequency, or channel while scanning. If you lock out a system or group, any channels belonging to that system or group are also locked out.

You can lock out up to 200 frequencies. The scanner skips locked-out frequencies while using the Close Call feature or while searching.

Feature Highlights

CTCSS and DCS Squelch Modes – prevent interference from stations not using the mode you select.

Dropout Delay – You can set whether the scanner pauses at the end of a transmission to wait for a reply. You can set the delay time for each system you scan, and while searching and using the Close Call feature.

Attenuator – You can set the scanner's attenuator to reduce the input strength of strong signals by about 18 dB received by the scanner.

Repeater Reverse – You can set the scanner so it switches to the input frequency on a conventional repeater system.

Channel Alert – You can set the scanner so it alerts you when there is activity on any channel you specify.

Memory Check – Lets you see at a glance how much total memory is left.

Frequency Step – Lets you select a frequency step (5, 6.25, 7.5, 10, 12.5, 15, 20, 25, 50 or 100 kHz) for manual mode and chain search mode. The scanner's auto step feature lets you set the scanner so it automatically chooses the correct step.

Quick Recall – Lets you quickly select a specific channel by choosing the system, group, and channel.

Scan/Search Delay – You can set the scanner so it remains on a frequency up to 5 seconds after the last transmission to wait for a possible reply.

Text Tagging – You can name each race system, conventional system, group, channel, custom search range, and SAME group, using up to 16 characters per name.

Unique Data Skip – Allows your scanner to skip unwanted data transmissions and reduces birdies.

Duplicate Frequency Alert – Alerts you if you try to enter a duplicate name or frequency already stored in the scanner.

Feature Highlights

Memory Backup – If power is lost or disconnected, the scanner retains the frequencies you programmed in its memory.

22 Bands – Includes 22 bands, with Aircraft and 800 MHz.

Note: The scanner's frequency coverage is not continuous and does not include the cellular telephone band.

Weather

Weather Search – Lets your scanner receive your local NOAA weather transmission.

SAME Weather Alert – Lets your scanner alert you when a SAME weather alert is transmitted on a NOAA weather channel. The scanner also displays the transmitted alert type. This helps you quickly find out about severe weather in your area and lets you avoid false alarms.

Search

Service Search – Lets you quickly select and search the scanner's preprogrammed frequencies.

Custom Search – Lets you program up to 10 custom search ranges. You can search any of these ranges simultaneously.

CTCSS/DCS Search – Lets the scanner search for CTCSS or DCS tones. You can identify up to 50 CTCSS tones and 104 DCS tones.

Quick Search – Lets you search from the currently-tuned frequency if you are searching a conventional system.

Auto Store

Frequency AutoStore – Automatically stores all active frequencies within a system you select.

Priority

Priority Scan – Priority channels let you keep track of activity on your most important channel(s) while monitoring other channels for transmissions.

Priority Plus – You can set the scanner so it scans only the priority channels

Feature Highlights

Backlight and Power

LCD Back Light – Makes the display easy to see in dim light. You can adjust the back light so it turns on when you press a key, when squelch breaks during a transmission, or manually.

Low Battery Alert – The scanner alerts you if the batteries need to be recharged or replaced.

Battery Save – You can set the scanner so it reduces the amount of power it needs if there are no transmissions.

Key Controls

Key Lock – You can deactivate the scanner's keys to help prevent accidentally changing the scanner's programming.

Key Beep – You can control whether the scanner beeps when you press a key.

PC Control and Cloning

PC Control – You can transfer programming data to and from your scanner and your personal computer, and control the scanner using a computer. This helps you find frequencies listed on the Internet and load them into the scanner.

Clone Mode – You can clone all programmed data, including the contents of the scanner's memory, menu settings, and other parameters from one SC230 scanner to another SC230 scanner.

On-Air Cloning – You can clone all programmed data over the air from one SC230 scanner to another SC230 scanner using a personal computer and a radio transmitter.

About This Manual

The screen displays used in this manual are representations of what might appear when you use your scanner. Since what you see depends on the frequencies for your area and the settings you select, you might notice some differences between what is in this manual and what appears on your scanner.

Feature Highlights

How the Scanner's Controls Are Represented in This Manual

To help navigate the scanner's menus, the steps shown in this manual show the displays you see and the keys you press or control you operate to get a desired result.

This example shows you how to use the scanner's menu to edit an existing system name. It shows you the key to press (**Menu**) to select a menu option and the option you see (*PROGRAM SYSTEM*) when you press **Menu**. It also instructs you to turn the scroll control (shown as **U**) to view a series of choices then select one choice (*EDIT NAME*).

Menu → *PROGRAM SYSTEM* → **E U** →
Select the system → **E U**
→ *EDIT NAME* → **E**

To get the most from this manual, review the contents to become familiar with the basic functions available. If you are new to scanning, be sure to read "Understanding Scanning" on Page 16 for a quick background on the technology. The first thing you'll need to do is install batteries in the scanner. Then you need to connect the included antenna to the scanner. See "Setting Up Your Scanner" on Page 23 if you need any help doing this.

Entering Text

To enter a letter, turn the scroll control until the character you want appears. To enter a number, press a number key. To enter a decimal point, press **.**

To move the cursor to the left, hold **Func** then press **</4** or rotate the scroll control to the left. To move the cursor to the right, hold **Func** then press **6/>** or rotate the scroll control to the right.

To clear a character, press **No** twice. To clear all characters, press **No** 3 times. To accept an entry, press **E** or press down on the scroll control.

Feature Highlights

Understanding Scanning

This section provides you with background on how scanning works. You don't really need to know all of this to use your scanner, but some background knowledge will help you get the most from your SC230.

Understanding the Scanner's Memory

Your scanner's memory is organized in an architecture called *Dynamic Allocated Channel* memory. This type of memory is organized differently and more efficiently than the bank/channel architecture used by traditional scanners. Dynamic Allocated design matches how radio systems actually work much more closely, making it easier to program and use your scanner and determine how much memory you have used and how much you have left.

Instead of being organized into separate banks and channels, your scanner's memory is contained in a *pool*. You simply use as much memory as you need in the pool to store as many frequencies and alpha tags as you need. No memory space is wasted, and you can tell at a glance how much memory you have used and how much remains.

What is Scanning?

Unlike standard AM or FM radio stations, most two-way communications do not transmit continuously. Your SC230 scans programmed channels until it finds an active frequency, then stops on that frequency and remains on that channel as long as the transmission continues. When the transmission ends, the scanning cycle resumes until the scanner receives another transmission.

What is Searching?

The SC230 can search each of its 22 bands and up to 10 banks together to find active frequencies. This is different from scanning because you are searching for frequencies that have not been programmed into the scanner. When you select frequency bands to search, the scanner searches for any active frequency within the

Understanding Scanning

lower and upper limits you specify. When the scanner finds an active frequency, it stops on that frequency as long as the transmission lasts. If you think the frequency is interesting, you can program it into the scanner's memory. If not, you can continue to search.

What is CTCSS/DCS?

Your scanner can monitor systems using a Continuous Tone Coded Squelch System (CTCSS) and Digital Coded Squelch (DCS) system, which allow squelch to open only when the tone you have programmed with a specific frequency is received along with a transmission.

CTCSS and DCS are subaudible tone signaling systems sometimes referred to as PL or DPL (Motorola's trademarked terms for Private Line and Digital Private Line respectively). CTCSS and DCS are used only for FM signals and are usually associated with both amateur and commercial two-way frequencies. These systems make use of a special subaudible tone that accompanies a transmitted signal.

CTCSS and DCS are used for many purposes. In many cases, CTCSS and DCS are used to restrict access to a commercial repeater, so that only those units, which transmit the correct tone along with their signal can "talk" to the repeater.

CTCSS and DCS are also used in areas that receive interference where there are several stations with output frequencies close to each other. When this occurs, you might hear multiple communications on the same frequency. The stations might even interfere with each other to the point where it is impossible to clearly receive any of the stations. A scanner equipped with CTCSS and DCS (like your scanner) can code each received frequency with a specific CTCSS or DCS frequency. Then, when you receive multiple signals, you only hear the transmission with the CTCSS or DCS tone you programmed. If you do not receive the correct tone with a signal, the scanner's squelch remains closed and you hear nothing.

Understanding Scanning

You can search for the following CTCSS frequencies and DCS codes.

CTCSS Frequencies (Hz)

67.0	69.3	71.9	74.4	77.0	79.7
82.5	85.4	88.5	91.5	94.8	97.4
100.0	103.5	107.2	110.9	114.8	118.8
123.0	127.3	131.8	136.5	141.3	146.2
151.4	156.7	159.8	162.2	165.5	167.9
171.3	173.8	177.3	179.9	183.5	186.2
189.9	192.8	196.6	199.5	203.5	206.5
210.7	218.1	225.7	229.1	233.6	241.8
		250.3	254.1		

DCS Codes (Octal)

023	025	026	031	032	036	043	047
051	053	054	065	071	072	073	074
114	115	116	122	125	131	132	134
143	145	152	155	156	162	165	172
174	205	212	223	225	226	243	244
245	246	251	252	255	261	263	265
266	271	274	306	311	315	325	331
332	343	346	351	356	364	365	371
411	412	413	423	431	432	445	446
452	454	455	462	464	465	466	503
506	516	523	526	532	546	565	606
612	624	627	631	632	654	662	664
703	712	723	731	732	734	743	754

Using the Scanner at the Racetrack

Keeping up with the action at the racetrack is easy and fun. You can hear drivers communicating with their pit crews, officials communicating with drivers and crews, and track workers communicating with everybody.

Each user at the racetrack transmits and receives on one or more frequencies.

The scanner organizes racetrack frequencies by the name of the race you are scanning and by car number. For example, you might hear drivers and their pit crews on the car number frequencies and officials and the news media on the race frequencies. When you are scanning, the scanner stops very briefly on each channel to see if there is activity. If there isn't, the scanner quickly moves to the next channel. If there is, then the scanner pauses on the transmission until it is over.

You can activate one racing system and as many conventional systems as you want at the same time. Within a racing system, each driver can have multiple frequencies stored.

Conventional Scanning

Conventional scanning is a relatively simple concept. Each group of users in a conventional system is assigned a single frequency (for simplex systems) or two frequencies (for repeater systems). Any time one of them transmits, their transmission always goes out on the same frequency. Up until the late 1980s, this was the primary way that radio systems operated.

Even today, there are many 2-way radio users who operate using a conventional system:

- Aircraft
- Amateur radio
- FRS/GMRS users
- Broadcast AM/FM/TV stations
- Many business radio users

Understanding Scanning

When you want to store a conventional system, all you need to know is the frequencies they operate on. When you are scanning a conventional system, the scanner stops very briefly on each channel to see if there is activity. If there isn't, the scanner quickly moves to the next channel. If there is, then the scanner pauses on the transmission until it is over.

Simplex Operation

Simplex systems use a single frequency for both transmit and receive. Most radios using this type of operation are limited to line-of-sight operation. This type of radio is frequently used at construction job sites, and with inexpensive consumer radios such as GMRS/FRS radios. The range is typically 1-8 miles, depending upon the terrain and many other factors.

Repeater Operation

Repeater systems use two frequencies: one transmits from the radio to a central repeater; the other transmits from the repeater to other radios in the system. With a repeater-based system, the repeater is located on top of a tall building or on a radio tower that provides great visibility to the area of operation. When a user transmits (on an input frequency), the signal is picked up by the repeater and retransmitted (on an output frequency). The user's radios always listen for activity on the output frequency and transmit on the input frequency. Since the repeater is located very high, there is a very large line of sight.

Typical repeater systems provide coverage out to about a 25-mile radius from the repeater location.

Where To Get More Information

By itself, this manual really only provides part of what you need to know to have fun scanning – how to program and use the scanner.

Information On The Internet

The Internet is a great source for current frequencies and information about scanning. Many web sites have lists of frequencies for your area. You can use a search engine to find and use them.

Make a list of the agencies you want to listen to, then look up the frequencies and systems used by those agencies. Here are a few useful sites:

- <http://www.scannermaster.com> * - frequency resources and home of Police Call.
You can also call them at 1 800 SCANNER (hours are from 9:00 a.m. to 5:30 p.m. Eastern Time Monday through Friday).
- <http://www.radioreference.com> * - the Internet's premier source for user-supported radio system information.
- <http://www.bearcat1.com> - frequency information from National Communications.
- <http://svartifoss2.fcc.gov/reports/index.cfm> * - conventional frequency information on file with the US Government
- <http://groups.yahoo.com/group/SC230> * - a group for people interested in discussing the SC230.

* - *These web sites are not affiliated with Uniden Corporation.*

For more information about Uniden and our other products, visit <http://www.uniden.com>.

Included With Your Scanner

If any of these items are missing or damaged, immediately contact your place of purchase or Uniden Customer Service at (800) 297-1023 during regular business hours (Central time).



Scanner

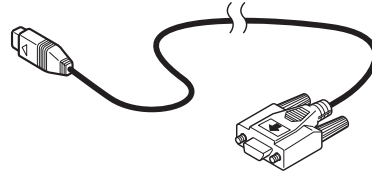

Connection
Cable

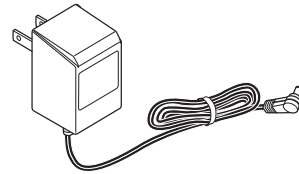

AC Adapter

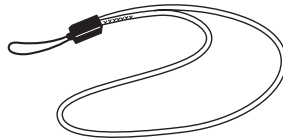

Wrist Strap

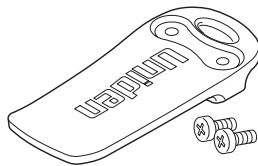

Belt Clip



Batteries

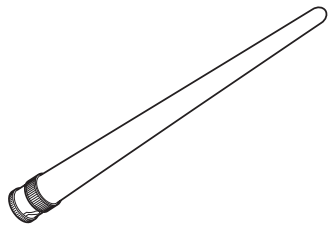

Antennas

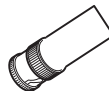

Owners
Manual

Included With Your Scanner

Setting Up Your Scanner

These guidelines will help you install and set up your new scanner:

- If your scanner receives interference or electrical noise, move the scanner or its antenna away from the source.
- To improve the scanner's reception, use an optional external antenna designed for multi-band coverage. (You can purchase this type of antenna at a local electronics store). If the optional antenna has no cable, use 50-70 Ω coaxial cable for lead-in. A mating plug might be necessary for the optional antennas.
- Use an optional mono earphone or mono headset with proper impedance (32 Ω) for private listening. Read the precautions on the inside front cover of this Owners Manual.
- Do not use the scanner in high-moisture environments such as the kitchen or bathroom.
- Avoid placing the scanner in direct sunlight or near heating elements or vents.

Using Internal Batteries

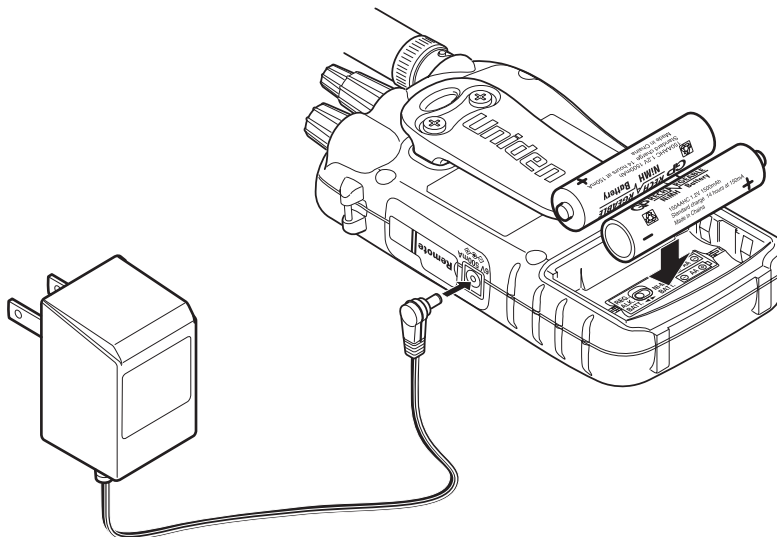

You can power your scanner using two alkaline, or rechargeable AA batteries.

Before installing batteries, set the switch in the battery compartment to match the type of batteries you will use. Select **REG. ALK. BATT.** for non-rechargeable battery types and **NI-MH. BATT.** for rechargeable battery types. See also “Using Rechargeable Batteries” on Page 25 when you use rechargeable batteries.

1. Remove the battery cover and set the battery switch.

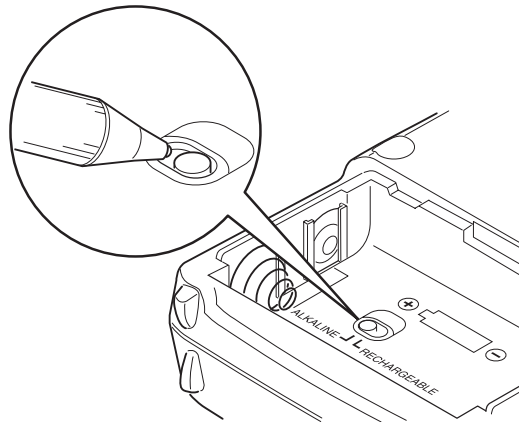

2. Install 2 AA batteries, matching the polarity symbols (+ -).

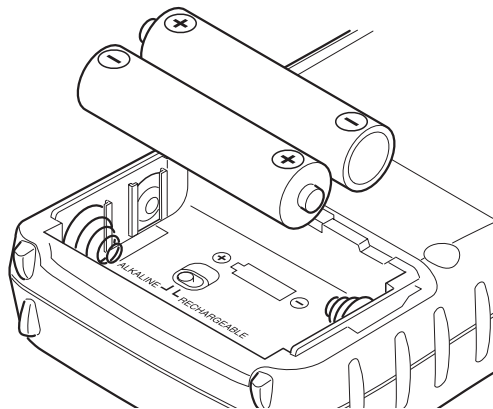

WARNING!

Set **REG. ALK. BATT./NI-MH. BATT.** to **NI-MH. BATT.** for use only with rechargeable batteries.
Never attempt to recharge non-rechargeable batteries. Non-rechargeable batteries can get hot and can even burst if you try to recharge them.

3. Replace the cover.

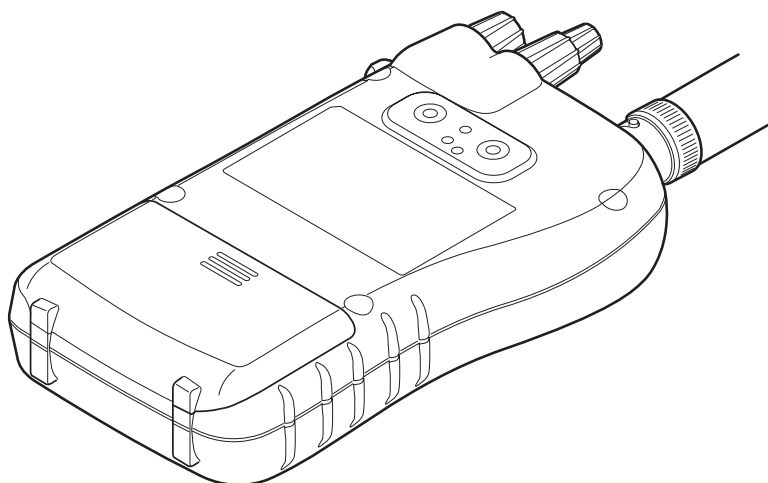

When **BATT** flashes and the scanner beeps every 15 seconds, replace both batteries.

Using Rechargeable Batteries

You can also use two rechargeable batteries to power your scanner. Before you use rechargeable batteries, you must charge them.

The scanner has a built-in circuit that lets you recharge batteries while they are in the scanner. To charge the batteries, set **REG. ALK. BATT./NI-MH. BATT.** inside the battery compartment to **NI-MH. BATT.**, install the batteries in the scanner, and connect the supplied AC adapter to the scanner's DC 6V jack (see "Using AC Power" on Page 26).

WARNING!

Do not connect the AC adapter to the scanner if non-rechargeable batteries (such as alkaline batteries) are installed in the scanner and **REG. ALK. BATT./NI-MH. BATT.** is set to **NI-MH. BATT.**, or if you are unsure of the switch's position. Non-rechargeable batteries can get hot and can even burst if you try to recharge them.

Before you use rechargeable batteries for the first time, charge them for 14 hours to bring them to a full charge.

Discharged batteries take about 14 hours to fully recharge.

Using AC Power

You can power the scanner using the supplied 6V, 500 mA AC adapter.

To use the scanner on AC power, plug the AC adapter into a standard AC outlet.

If rechargeable batteries are installed and **REG. ALK. BATT./NI-MH. BATT.** is set to **NI-MH. BATT.**, the adapter powers the scanner and recharges the installed batteries at the same time.

Connecting the Antenna

To attach the supplied stub antenna to the connector on the top of your scanner, align the slots around the antenna's connector with the tabs on the scanner's BNC connector. Then slide the antenna's connector down over the scanner's connector and rotate the antenna connector's outer ring clockwise until it locks into place.

Connecting an Optional Antenna

The scanner's BNC connector makes it easy to connect a variety of optional antennas, including an external mobile antenna or outdoor base station antenna.

Note: Always use 50-ohm, RG-58, or RG-8, coaxial cable to connect an outdoor antenna. If the antenna is over 50 feet from the scanner, use RG-8 low-loss dielectric coaxial cable. You can get a BNC adapter at your local electronics store.

Connecting an Earphone/Headphone

For private listening, you can plug a 1/8-inch (3.5 mm) mini-plug earphone or headphones (not supplied) into the headphone jack on top of your scanner.

This automatically disconnects the internal speaker. See “Earphone Warning” at the front of the manual for important information about using an earphone/headphone.

Connecting an Extension Speaker

In a noisy area, an optional amplified extension speaker, positioned in the right place, might provide more comfortable listening. Plug the speaker cable's 1/8-inch (3.5-mm) mini-plug into your scanner's jack.

WARNING!

If you connect an external speaker to the scanner's headphone jack, never connect the audio output line to a power supply and ground. This might damage the scanner.

Attaching the Belt Clip

To make your scanner easier to carry when you are on the go, use the supplied belt clip. Use a Phillips screwdriver and the supplied screws to attach the clip to the scanner.

Attaching the Wrist Strap

To keep your scanner safely close at hand, use the supplied wrist strap. Push the small loop on one end of the wrist strap through the lug on the right side of the scanner, then thread the other end of the wrist strap back through the small loop to secure it.

Installing the Demo Software

You can operate your scanner using a personal computer and the free demo software available at <http://www.uniden.com>.

Download the software, then double-click on the install package to begin installation. The SC230 Install program installs the software. You must install the software to use the scanner with your computer.

After you install the SC230 Install program, start it by double clicking on the desktop icon or by selecting it in the Start Programs list.

You can upgrade the included software to a full version by purchasing a registration key at <http://www.uniden.com>.

A Look At The Keypad

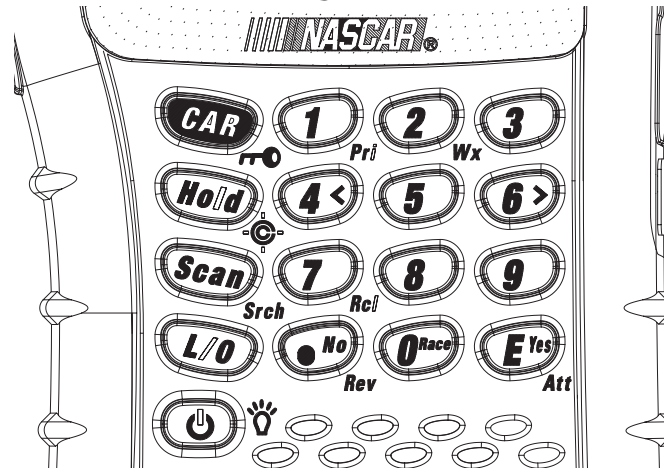





Your scanner's keys have various functions labeled on the key tops and below the keys. To select the function labeled on a key, simply press the key. To select the function labeled below a key, hold down **Func** on the left side of the scanner then press the key. **F** appears on the display.

If your scanner's keys seem confusing at first, the following information should help you understand each key's function.

Key Name	Description
CAR/	CAR – Selects a car in scan mode. Func + – Locks and unlocks the keypad.
Hold/	Hold – Holds the scan or the frequency search. Func + – Quickly turns the Close Call feature on or off (see “Setting Close Call Options” on Page 73).
Scan/Srch	Scan – Scans the stored channels. Func + Srch – Starts quick search or quickly accesses the search menu.

Setting Up Your Scanner

Key Name	Description
L/O	<p>L/O – Lets you lock out a selected channel or skip a specified frequency.</p> <p>[Func] + L/O – Press quickly to lock and unlock a selected system in Scan or Scan Hold mode and review search lockout frequencies in Search or Search Hold mode. Press and hold for more than 2 seconds to unlock all groups and channels in a system.</p>
 / 	<p> – Press and hold for more than 2 seconds to turn the scanner on or off. Press quickly to cancel a prompt.</p> <p>[Func] +  – Turns the display backlight on or off.</p>
1-9, 0/Race	<p>1-9 – Enters a frequency, enters quick key numbers, selects a custom search range in Custom Search mode, and selects systems by quick key in scan mode.</p> <p>0/Race – Selects the race quick key, enters a frequency, and selects a custom search range in Custom Search mode.</p> <p>[Func] + 1-9, 0/Race – Selects groups by quick key in scan mode.</p>
1/Pri	<p>1 – Enters a 1.</p> <p>[Func] + Pri – Selects the priority mode in scan hold mode.</p>

Key Name	Description
2/Wx	<p>2 – Enters a 2.</p> <p>[Func] + WX – Selects the weather function in the menu in the Hold mode.</p>
4/ <	<p>4 – Enters a 4.</p> <p>[Func] + < – Moves the active character to the left while editing data.</p>
6/ >	<p>6 – Enters a 6.</p> <p>[Func] + > – Moves the active character to the right while editing data.</p>
7/Rcl	<p>7 – Enters a 7.</p> <p>[Func] + Rcl – Displays a series of prompts to quickly select a specific channel in the scan hold mode.</p>
No/ • /Rev	<p>• – Enters a decimal point or dash in a frequency.</p> <p>At a prompt, answers “No.”</p> <p>[Func] + Rev – Monitors the currently-tuned frequency’s reverse frequency.</p>
E/Yes/Att	<p>E – Press to select input and menu items, to quickly edit a channel in Scan Hold Mode, and store a frequency into memory in Search Hold mode.</p> <p>At a prompt, answers “Yes.”</p> <p>[Func] + Att – Turns the scanner’s attenuator on or off for the current channel.</p>

A Look At The Display

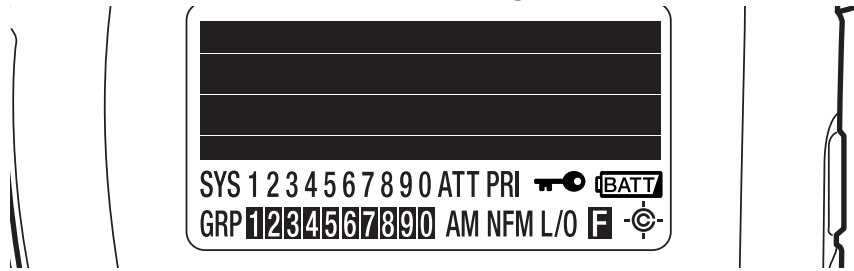



The display has indicators that show the scanner's current operating status. The display information helps you understand how your scanner operates. The dark area shown above the icons in this illustration is the text display area. Information about the currently tuned frequency appears here.

SYS - shows the currently activated system, appears with numbers (1-9). The currently active system indicator flashes.

PRI - appears when the priority feature is turned on (see “Priority Scan” on Page 40).



 - appears when you lock the keypad (see “Locking/Unlocking the Keypad” on Page 40).

 - alerts you when the battery power gets low.

GRP - shows the currently activated group, appears with numbers (-). The currently active group indicator flashes.

AM/FM/NFM - appears to show the type of transmission.

L/O - appears when you manually select a channel you locked out or a skip frequency.

 - appears when you hold down  to select a function.

 - appears when the scanner is set to a Close Call feature mode (see “Using the Close Call Feature” on Page 72).

Using Menu

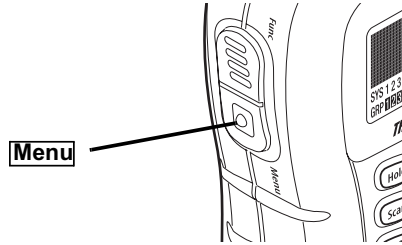

Press **Menu** on the left side of the scanner to enter the menu. See “Using the Menu” on Page 44 for more information about the scanner’s menu options.

Using Func

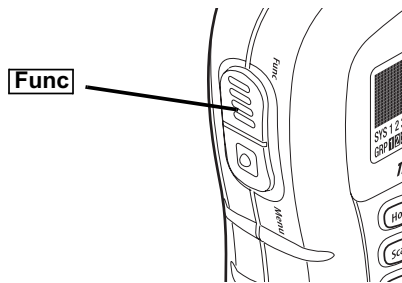

To select the function labeled below a key on the front of the scanner, hold down **Func** on the left side of the scanner, then press that key. To hold on a system while scanning or temporarily stop on a channel while searching, press **Func**. To select a system in Scan or Scan Hold mode, hold down **Func** and rotate the scroll control.

Using the Scroll Control

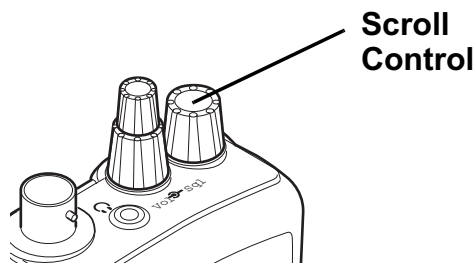

Turn the scroll control on top of the scanner to select a channel or frequency in Hold mode, select menu items in Menu mode, and to select a character while editing a name. You can also press the scroll control down instead of pressing **E** on the keypad to select an item.

Basic Operation

Turning On the Scanner and Setting the Squelch

Note: Make sure the scanner's antenna is connected before you turn it on.

1. Turn **SqI** fully counterclockwise.
2. Press and hold  for about 2 seconds to turn on the scanner, then turn **Vol** clockwise until you hear a hissing sound.
3. Turn **SqI** clockwise until the hissing stops.

Scanning Systems

To begin scanning programmed systems, press **Scan**. The SC230 scans all unlocked systems in all activated quick-key groups.

Notes:

- If no systems are programmed, or all systems are locked out, an error message appears. Program a system or select a system to scan.
- When scanning multiple systems, the SC230 scans systems according to the assigned quick key. Then the race assigned to the next quick key (1, 2, 3, 4, etc.) is scanned. Systems not assigned to a quick key are scanned last. Within a quick key, systems are scanned in the order they were assigned.
- Within a system, channels are scanned according to the assigned channel group, with the same priority as described above for systems.
- The SC230 scans a system for the duration you set using the System Hold Time option (see “Setting the System Hold Time” on Page 56). All unlocked channels are scanned at least one time regardless of the hold time setting.

Scanning Preprogrammed Races

Before You Get To The Track

Each driver's team has several different frequencies they can use during a race. These frequencies can change depending on local interference sources or other frequency issues. Your scanner is preprogrammed with all of the drivers and their possible frequencies that were known when it was manufactured.

Before you leave for the track, check the Internet to see if there are any frequency updates available for your race. You can save time at the track by setting up as much as possible before you leave.

When You Get To The Track

When you arrive at the race, get a list of the actual frequencies in use that race day. These are normally available for sale on the way into the facility. This list will show the actual frequency being used by each driver that day, as well as some other useful frequency information. Then, follow the steps in the sections below to adjust the scanner settings.

Selecting Driver Frequencies

Follow these steps to select the appropriate frequency for each driver.

1. Press **0**, rotate the scroll control to select the race, then press **E**.
2. Press **CAR**, enter the driver's number, then press **E**. Or press **CAR**, press **E**, rotate the scroll control to select the driver, then press **E**.
3. Rotate the scroll control to select the driver's frequency. If the driver's frequency is not listed, select *NEW FREQUENCY* then enter the correct frequency.
4. Press **Hold** to set the selection.

Holding on a Car

Follow these steps to hold on a car within the currently-selected racing system.

-
-
1. Press **0**, rotate the scroll control to select the race, then press **E**.
 2. Press **CAR**, enter the driver's number, then press **CAR**. Or press **CAR** twice, rotate the scroll control to select the driver, then press **CAR**. You can select the car's first unlocked frequency.

Selecting Interference Eliminator Codes

Many drivers use special codes in their radios to prevent interference from other nearby radio systems. These codes are commonly referred to as CTCSS, DCS, or subaudible tones. You can use these same codes to prevent interference from other systems.

1. Press **0**, rotate the scroll control to select the race, then press **E**.
2. Press **CAR**, enter the driver's number, press **E** or **CAR**, press **E**, rotate the scroll control to select the driver, then press **E**.
3. Rotate the scroll control to select the driver's frequency, then press **E**.
4. Press **E** to enter the channel setting menu.
5. Rotate the scroll control to select *SET CTCSS/DCS*, then press **E**.
6. Enter the correct CTCSS/DCS value, then press **E**.
7. Press **Hold** to set the selection

Selecting Systems to Scan

To select systems to scan, press **Scan** then press the number button corresponding to the quick key assigned to the system or systems. To stop scanning the system(s), press **Scan** again.

The SYS indicators on the display show the systems that are currently selected.

To select or lock out a system that is not assigned to a key, press and hold **FUNC** while you rotate the scroll

control until the desired system is selected. Then, continue to hold **FUNC** and press **L/O** to either lock out or unlock the system.

Selecting System Channel Groups

Within a system, you can assign groups of channels to a group quick key (see “Setting the Group Quick Key” on Page 59).

Follow these steps to activate or deactivate a channel group within a system while scanning.

1. Press **Func** to hold on the system (or hold **Func** and rotate the scroll control to select the system).
2. Continue to hold **Func** and press the number key corresponding to the channel group you want to activate or deactivate.

Locking/Unlocking Systems

Follow these steps to lock out a system so that it does not scan even if its quick key is selected.

1. While holding down **Func**, rotate the scroll control to select the system.
2. Continue to hold down **Func** and press **L/O** to lock out the system.
3. Repeat Steps 1 and 2 to unlock a system you have previously locked.

Note: You can unlock only one race at a time. When you unlock a race, the scanner automatically locks the other races.

Locking/Unlocking Channels

Follow these steps to lock out a channel so that it does not scan even if its system and channel group are selected.

1. While holding down **Func**, rotate the scroll control to select the system where the channel is stored.

-
-
2. Release **[Func]** then press **Hold** within 2 seconds to hold on the system.
 3. Rotate the scroll control to select the channel you want to lock or unlock.
 4. Press **L/O** to lock or unlock the channel.

You can also lock out an active channel by pressing **L/O** while the scanner is stopped on the channel.

Temporarily Holding On a System

To temporarily hold on a system, press and hold **[Func]**. To hold on a different system, continue to hold **[Func]** and rotate the scroll control to select the system. Normal scanning resumes 2 seconds after you release **[Func]**.

Holding On a Channel

To hold on a channel, press **Hold** while the channel is active. To select a different channel, rotate the scroll control. If you scroll past the beginning or end of the current system, the scanner selects channels in the previous or next system. To resume scanning, press **Scan**.

Note: You can select any channel (locked or unlocked).

Quick-Storing Channels

1. Hold on an existing channel in any system.
2. Enter the frequency you want to store.
3. To quick-store the channel, press **E**. Otherwise, press **No**.

If you enter a frequency then press **E**, the scanner stores it in the *QCK SAVE GRP* group in a system called *QCK SAVE CNV SYS*. These are created if they do not exist. Then, the scanner prompts you to save other channel settings.

If you pressed **No** in Step 3, the scanner prompts you to select the system and the group where you want to store the frequency.

Quickly Recalling Channels

1. Press **Hold** to hold on any channel.
2. Press **Func** + **Rcl**. The scanner prompts you to select the system where the channel is stored.
3. Rotate the scroll control to select the system, then press **E**. The scanner prompts you to select the channel group where the channel is stored.
4. Rotate the scroll control to select the group, then press **E**.

If you selected a conventional system, the scanner prompts you to select a channel. Rotate the scroll control to select the channel, then press **E** to hold on that channel.

Otherwise, if you selected a racing system, the scanner automatically selects an active channel from the car group and holds on that group.

Other Settings

Displaying System Information

Viewing Memory Used

Menu → ↻ SEE SCANNER INFO → **E** ↻
% MEMORY USED → **E**

A bar showing the percent of memory used appears.
Press any key to return to the previous menu.

Viewing the Firmware Version

Menu → ↻ SEE SCANNER INFO → **E** ↻
FIRMWARE VERSION → **E**

Press any key to return to the previous menu.

Adjusting the Key Beep

Menu → ↻ ADJUST KEY BEEP → **E**

- *OFF*: The scanner is silent when you press a key.
- *ON*: The scanner beeps when you press a key.

Locking/Unlocking the Keypad

Press and hold down **Func** then **CAR/**  to lock or unlock the keypad.

Turning Power Save On or Off

Menu → ↻ SET BATTERY SAVE → **E**

- *ON*: The scanner goes into low-power mode when you monitor a conventional channel that has no activity.
- *OFF*: Power save is off.

Priority Scan

Menu → ↻ SET PRIORITY → **E**

Or, while holding on any channel, press **Func** + **1/Pri** to select one of these priority modes:

Other Settings

- *PRIORITY OFF*: Normal scanning
- *PRIORITY ON*: While scanning, the scanner interrupts every 2 seconds and checks the priority channels in each unlocked system. Priority channels in lower priority key numbered systems (starting from 1) have highest priority. *PRI* appears when you select this mode.
- *PRIORITY PLUS*: The scanner only scans priority channels in unlocked systems. *PRI* flashes when you select this mode.

Using the Backlight

Menu → ↻ *SET BACKLIGHT* → **E**

- *10 SEC* The backlight stays on for 10 seconds after you press **Func** + 🖱.
- *30 SEC* The backlight stays on for 30 seconds after you press **Func** + 🖱.
- *SQUELCH* The backlight turns on when the squelch opens then stays on for 5 seconds.
- *KEYPRESS* The backlight turns on when any key is pressed then stays on for 10 seconds.
- *INFINITE* The backlight turns on when you press **Func** + 🖱 then stays on until you press **Func** + 🖱 again.

Pressing any key while the backlight is on extends the backlight period. Pressing **Func** + 🖱 while the backlight is on turns off the backlight.

Initializing the Scanner's Memory

Important! This deletes all preprogrammed data. You cannot restore preprogrammed data that has been deleted.

To initialize the scanner's memory, turn off the scanner. Then, press **2**, **9**, and **Hold** while turning it on.

Other Settings

Using the PC Control and Cloning Options

Use the included connection cable to connect your scanner to another SC230 scanner or your personal computer.

Menu → ↻ *XFER INFORMATION* → **E**

- *PC CONTROL* Lets you set the baud rate your scanner uses to communicate with a personal computer. See “Connecting Your Scanner to a Personal Computer”.
- *WIRED CLONE* Lets you set your scanner as a master or a slave, letting you transfer programming to or from another SC230 scanner. See “Cloning the Scanner” on Page 43.
- *ON-AIR CLONE* Lets you clone all programmed data over the air to or from another SC230 scanner.

Connecting Your Scanner to a Personal Computer

To connect your scanner to a personal computer, you must first set the scanner’s baud rate (the rate at which data is transferred between the scanner and the computer, in bits per second (bps)).

Hint: If you have trouble transferring data between your scanner and your computer, try setting the baud rate to a slower setting.

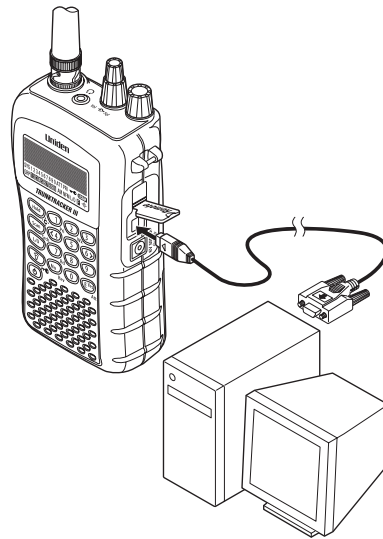

Menu → ↻ *XFER INFORMATION* → **E** → *PC CONTROL* → **E** → ↻

- *OFF* The baud rate is not set.
- *9600 BPS* The baud rate is set to 9600 bps.
- *19200 BPS* The baud rate is set to 19,200 bps.
- *38400 BPS* The baud rate is set to 38,400 bps.
- *57600 BPS* The baud rate is set to 57,600 bps.

Other Settings

Cloning the Scanner

To clone (copy) data from one SC230 scanner to another SC230 scanner, you must first connect the scanners to each other using the included connection cables and a DB9 null modem adapter and DB9 gender changer (neither included), available at most computer stores. Then you must set one scanner as the master (source) and the other as the slave (destination).

Note: You can also copy data to your SC230 scanner using a radio transmitter and a personal computer.

Plug the smaller end of each of the included connection cables into **Remote** on the right side of each scanner. Then connect the other end of the cables together using the null modem connector and gender changer.

Then set up both scanners.

Menu → ↻ *XFER INFORMATION* → **E** →
WIRED CLONE → **E** → ↻

- *MASTER* This will be the master (source) scanner.
- *SLAVE* This will be the slave (destination) scanner.

(Master scanner) **E** → *CLONE MASTER PRESS SCAN KEY*

(Slave scanner) **E** → *CLONE SLAVE PRESS SCAN KEY*

When you are ready to clone the scanner, press **Scan** on the slave scanner first, then on the master scanner.

The master scanner checks the connection between the two scanners, then transfers its data to the slave scanner.

When the transfer is complete, *COMPLETE* appears on both scanners. If the transfer did not work, *ERROR* appears on the master scanner.

Other Settings





Using the Menu

The scanner's menu lets you select options that let you set up and use the scanner.

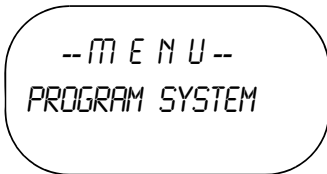
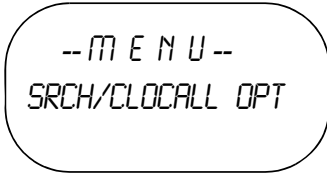
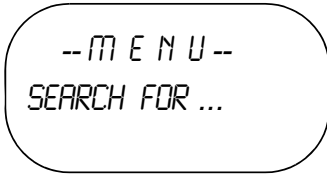
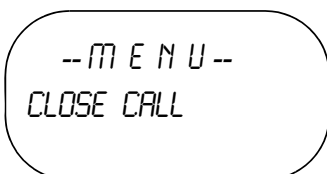
To use the menu, press **Menu** on the left side of the scanner. In most cases, the current menu position appears on the upper line of the menu. Menu items and a place to input information appear on the lower line of the menu. To select a menu item, turn the scroll control on top of the scanner clockwise or counterclockwise. When the menu item you want to select appears, press **E** or press the scroll control down to select it. To back up a level or return to the previous level, press **Menu**. To exit the menu mode, press **Scan**.

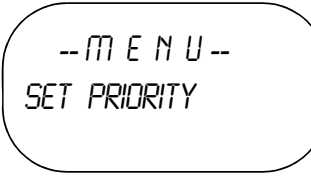
This table shows the available menu options and where you can find more information about how to use them.

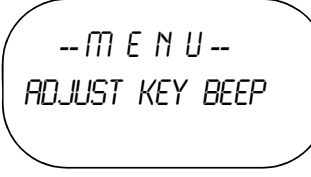
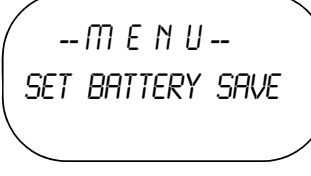
Menu Item	Lets You ...	See ...
	Set up the scanner's scan options.	"Programming Radio Systems" on Page 46.
	Set up the scanner's Close Call option.	"Using the Close Call Feature" on Page 72.
	Set up the scanner's search option.	"Searching and Storing" on Page 67.
	Set up the scanner's Close Call operation.	"Setting Close Call Options" on Page 73.

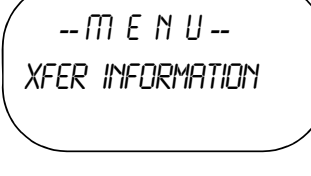
Menu Item	Lets You ...	See ...
	Set up priority options.	"Priority Scan" on Page 40.
	Set up weather options.	"Using Weather Alert (SAME)" on Page 80.
	Set up backlight options.	"Using the Backlight" on Page 41.
	Set up key beep options.	"Adjusting the Key Beep" on Page 40.
	Set up battery save options.	"Turning Power Save On or Off" on Page 40.
	View information about your scanner.	"Displaying System Information" on Page 40.
	Transfer information between it and your personal computer.	"Installing the Demo Software" on Page 28 and "Using the PC Control and Cloning Options" on Page 42.

Using the Menu

Programming Radio Systems

Your SC230 comes preprogrammed with the major analog systems used in the 25 most populous counties in the US. However, to get the most enjoyment from your scanner (especially if you do not live near one of these counties), you must customize the programming for your area.

To edit an existing system, use the menu to navigate to the system setting you want to change. This section assumes you are programming a new system.

Programming radio systems is completed in two major steps. Don't skip either step!

1. Plan the system.
2. Program the system into your scanner according to the plan you prepared in Step 1.

To make planning easier, planning worksheets are included in the back of this manual for each system type. Copy the worksheets (or download this manual from the Uniden America Corporation website and print extra sheets), then use them to plan out how you will program the scanner.

Important! Before you start programming your scanner, make sure the batteries are fresh or fully charged. If the scanner loses power while you program it, its memory might be corrupted which will require you to reinitialize it (see "Initializing the Scanner's Memory" on Page 41). All information programmed in the scanner, including preprogrammed systems, might be lost.

General Notes

- You can store up to 200 systems.
- The number of system channels you can have is limited only by the amount of scanner memory remaining.
- You can store up to 20 channel groups per conventional system.
- Total channels are limited to about 2500.
- Channels that have text tags use more memory than those that do not. If you use a text tag for every channel, total channels are reduced from 2500 (1600 is typical).

Programming Radio Systems

Quickly Programming Racing Systems

You can use the menu system to program a racing system (see “Manually Programming Racing Systems” on Page 49). Or you can follow the onscreen prompts as described in this section to quickly program your scanner. These prompts are designed to help you quickly enter a new race from a frequency list purchased at the track (if the system is not already preprogrammed into your scanner). When you complete Steps 5 and 6, almost all cars will use the default settings for the other steps.

1. While scanning, press **0**. Then rotate the scroll control to select *NEW RACE*, then press **E**.

```
SELECT RACE
NEW RACE
```
2. Enter the name of the race, then press **E**.

```
NAME THE RACE
-
SYS
GRP
```
3. Enter the first car number (up to 3 digits), then press **E**.

```
ENTER CAR NO
-
SYS
GRP
```
4. Enter the first driver name (up to 12 characters), then press **E**.

```
ENTER DRIVER
-
SYS
GRP
```
5. Enter the driver's frequency, then press **E**.

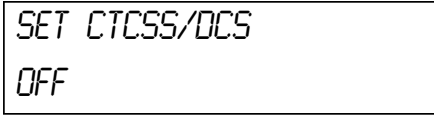
```
ENTER FREQUENCY
-
SYS
GRP
```
6. Set the CTCSS/DCS code, then press **E**.

```
SET CTCSS/DCS
OFF
```
7. Press **E** to enter advanced options (Steps 8-11) or press
 - to skip to Step 12.

Programming Radio Systems

-
-
8. Set the modulation type (*AUTO* is almost always the correct choice), then press **E**

SET MODULATION
AUTO

 9. Set the attenuator (turn it on to eliminate interference from other sources), then press **E**

SET ATTENUATOR
OFF

 10. Set the channel priority (turn it on if you want the scanner to interrupt operation every few seconds to check for transmissions by this driver), then press **E**

SET PRIORITY
OFF

 11. Set alert (turn it on if you want the scanner to sound a special alert when this car transmits), then press **E**

SET ALERT
OFF

 12. If you have another frequency to enter for this driver, press **E** then repeat from Step 5. Otherwise, press **No**

ANOTHER FREQ FOR THIS DRIVER?

 13. To enter another car in this race, press **E** then repeat from Step 3. Otherwise, press **No**

ANOTHER CAR FOR THIS RACE?

 14. When you finish, press **Scan** to begin scanning the race

COMPLETE
PRESS SCAN KEY

Manually Programming Racing Systems

Menu → PROGRAM SYSTEM → E
NEW SYSTEM → E → ↻ RACING → E →
CONFIRM? → E

The scanner creates an empty conventional system, with a default name of *SYSTEM NNN R*. *NNN* increments as you add new systems. *R* indicates that this is a racing system.

Refer to the appropriate section to set system-wide options:

- See “Editing the System Name” on Page 55
- See “Setting System Lockout” on Page 56
- See “Setting the System Hold Time” on Page 56
- See “Setting the Channel Delay Time” on Page 57
- See “Setting Data Skip” on Page 57
- See “Deleting Systems” on Page 58
- See “Copying Systems” on Page 58

Editing the Car

Menu → PROGRAM SYSTEM → E ↻
Select the system → E ↻
EDIT CAR → E ↻
Select the car → E

Follow these steps to enter the car options.

1. Press **0-9** to enter the car’s number, then press **E**.
2. Rotate the scroll control to select one of the following options. Then refer to the appropriate section to set or change a car setting.
 - See “Entering/Editing a Car Number” on Page 50.
 - See “Editing a Driver” on Page 50.
 - See “Setting a Car’s Quick Key” on Page 51.
 - See “Editing a Car’s Channel” on Page 51.
 - See “Deleting a Car” on Page 51.
 - See “Setting Lockout On A Car” on Page 52.

Entering/Editing a Car Number

Menu → PROGRAM SYSTEM → **E** ↻

Select the system → **E** ↻

EDIT CAR → **E** ↻

Select the car → **E** ↻

EDIT CAR NO → **E**

1. Rotate the scroll control to select the first digit, then press **0-9** to enter the correct digit.
2. Repeat Step 1 to enter or correct the second and third digits if necessary, Then press **E** or press down on the scroll control to accept the setting.

Hints:

- Each car number can be up to three digits.
- Press • to delete the entire car number.

Editing a Driver

Menu → PROGRAM SYSTEM → **E** ↻

Select the system → **E** ↻

EDIT CAR → **E** ↻

Select the car → **E** ↻

EDIT DRIVER → **E**

1. Rotate the scroll control to select the first letter.
2. Press and hold down **Func** then rotate the scroll control once to select the next letter.
3. Repeat Steps 1 and 2 until you have entered the driver's name. Then press **E** or press down on the scroll control to accept the setting.

Hints:

- Each driver's name can be up to 12 characters. Abbreviate as necessary to fit.
- Press • twice to delete the current character.
- Press • three times to clear the entire driver name.

Setting a Car's Quick Key

Menu → PROGRAM SYSTEM → E ↻

Select the system → E ↻

EDIT CAR → E ↻

Select the car → E ↻

SET QUICK KEY → E

After selecting this option, press **0-9** or rotate the scroll control to assign the car to a quick key or press **No** to assign the car to no quick key, then press **E**.

Hints:

- You can assign as many cars to the same quick key as you want.
- Preprogrammed conventional systems are set to quick key 9.
- To be scanned, a car's quick key must be activated and the system must be unlocked.

Editing a Car's Channel

Menu → PROGRAM SYSTEM → E ↻

Select the system → E ↻

EDIT CAR → E ↻

Select the car → E ↻

EDIT CHANNEL → E

Deleting a Car

Menu → PROGRAM SYSTEM → E ↻

Select the system → E ↻

EDIT CAR → E ↻

Select the car → E ↻

DELETE CAR → E

The scanner prompts you to confirm deletion. To confirm, press **E**. To cancel, press **No**.

Note: Deleted cars cannot be restored. You must re-enter them.

Setting Lockout On A Car

Menu → PROGRAM SYSTEM → E ↻

Select the system → E ↻

EDIT CAR → E ↻

Select the car → E ↻

SET LOCKOUT → E

This setting determines whether the scanner will scan this car when it is enabled. Select your setting, then press **E**.

LOCKOUT - the car is not scanned.

UNLOCKED - the car is scanned.

Note: The default setting is Unlocked.

Programming Conventional Systems

Menu → PROGRAM SYSTEM → E ↻

NEW SYSTEM → E ↻ → CONVENTIONAL →

E → CONFIRM? → E

The scanner creates an empty conventional system, with a default name of SYSTEM *NNN* *C*. *NNN* increments as you add new systems. *C* indicates that this is a conventional system.

Refer to the appropriate section to set system-wide options:

- See “Editing the System Name” on Page 55
- See “Editing the System Quick Key (Conventional Systems Only)” on Page 55
- See “Setting System Lockout” on Page 56
- See “Setting the System Hold Time” on Page 56
- See “Setting the Channel Delay Time” on Page 57
- See “Setting Data Skip” on Page 57
- See “Deleting Systems” on Page 58
- See “Copying Systems” on Page 58
- See “Entering/Editing Conventional Channel Groups” on Page 53

Programming Radio Systems

Entering/Editing Conventional Channel Groups

To enter channels in a conventional system, first set up a channel group (or groups) to hold the channels. Then, enter the channel and channel parameters in the group(s).

Setting Up a Channel Group

↻ → *EDIT GROUP* → **E** →

↻ → *NEW GROUP* → **E**

The scanner creates a group with a default name of *GROUP NN*. *NN* increments by one for each new group you create within a system.

Refer to the appropriate section to set group-wide options:

- See “Entering/Editing the Group Name” on Page 58
- See “Setting the Group Quick Key” on Page 59
- See “Deleting Groups” on Page 60
- See “Setting System Lockout” on Page 56
- See “Entering/Editing Conventional Channels” on Page 53

Entering/Editing Conventional Channels

↻ → *EDIT CHANNEL* → **E** →

↻ → *NEW CHANNEL* → **E** → *INPUT FREQUENCY*

Enter the frequency for the channel, then press **E**. Then, refer to the appropriate section to change a channel setting:

- See “Editing the Channel Name (Conventional Systems Only)” on Page 60
- See “Setting Channel Priority” on Page 61
- See “Setting Channel Alert” on Page 62
- See “Deleting Channels” on Page 65
- See “Copying/Pasting Channels” on Page 66

To program another channel within the same group, press **Menu**, then repeat the above.

To create another channel group and enter more channels, press **Menu** four times, then proceed from “Setting Up a Channel Group” on Page 53.

Programming/Editing Optional Settings

This section details the instructions for each of the optional programming steps referred to in “Programming Radio Systems” on Page 46. Use the instructions in the appropriate section to enter or edit a setting.

System-Level Settings

These settings apply to the entire system.

Editing the System Name

Menu → PROGRAM SYSTEM → **E** ↻

Select the system → **E**

EDIT NAME → **E**

Follow these steps to enter/edit the system name.

1. Rotate the scroll control to select the first letter.
2. Press and hold down **Func** then rotate the scroll control once to select the next letter.
3. Repeat Steps 1 and 2 until you have entered the system name. Then press **E** or press down on the scroll control to accept the setting.

Hints:

- Each system name can be up to 16 characters. Abbreviate as necessary to fit.
- The default system names include **C** (conventional) or **R** (race) in the 16th position to indicate the system type:
- Press **•** twice to delete the current character.
- Press **•** three times to clear the entire alpha tag.

Editing the System Quick Key (Conventional Systems Only)

Menu → PROGRAM SYSTEM → **E** ↻

Select the system → **E** ↻

EDIT SYS OPTION → **E** ↻

SET QUICK KEY → **E**

Programming/Editing Optional Settings

After selecting this option, press **1-9** to assign the system to a quick key or press **No** to assign the system to no quick key, then press **E**.

Hints:

- You can assign as many systems to the same quick key as you want.
- Preprogrammed conventional systems are set to quick key 9.
- To be scanned, a system's quick key must be activated and the system must be unlocked.

Setting System Lockout

Menu → PROGRAM SYSTEM → **E** ↻

Select the system → **E** ↻

EDIT SYS OPTION → **E** ↻

SET LOCKOUT → **E**

This setting controls whether the system is scanned when its quick key is enabled. Rotate the scroll control to select your setting, then press **E**.

LOCKED - the system is not scanned

UNLOCKED - the system is scanned

Note: You can also lock or unlock a system by pressing **Func**, selecting the system, then pressing **Func** + **L/O**.

Setting the System Hold Time

Menu → PROGRAM SYSTEM → **E** ↻

Select the system → **E** ↻

EDIT SYS OPTION → **E** ↻

SET HOLD TIME → **E**

This setting controls how many seconds the scanner scans a system before moving to the next unlocked system. Enter a value from 0-255, then press **E** to save the setting.

Notes:

- If you select 0, the scanner stays on the system for a minimal time (only long enough to check current system activity).
- The default setting is 2 seconds for each system.
- All unlocked channels will be scanned at least once regardless of this setting.
- The scanner moves to the next system after the hold time expires, any current transmission ends, and the channel delay time expires.

Setting the Channel Delay Time

Menu → PROGRAM SYSTEM → E ↻
Select the system → E ↻
EDIT SYS OPTION → E ↻
SET DELAY TIME → E

This setting controls how many seconds the scanner waits after a transmission ends before resuming scanning. Enter a value from 1-5 or OFF, then press E.

Notes:

- The default setting is 2 seconds for each system.
- This setting applies to all channels within the system.

Setting Data Skip

Menu → PROGRAM SYSTEM → E ↻
Select the system → E ↻
EDIT SYS OPTION → E ↻
SET DATA SKIP → E

This setting controls how the scanner behaves when it stops on a channel that has a data signal.

ON - the scanner stops briefly on the channel, but then immediately resumes scanning automatically. Press E to select.

OFF - the scanner remains on the channel until the transmission stops. Press E to select.

Notes:

- This setting is ignored for AM channels.
- The default setting for this feature is *ON*.

Deleting Systems

Menu → *PROGRAM SYSTEM* → **E** ↻

Select the system → **E** ↻

DELETE SYSTEM → **E**

The scanner prompts you to confirm deletion. To confirm, press **E**. To cancel, press **No**.

Notes:

- Deleted systems cannot be restored. You must re-enter them.
- You cannot restore preloaded systems.

Copying Systems

To copy a system including all settings, groups, and channels:

Menu → *PROGRAM SYSTEM* → **E** ↻

Select the system → **E** ↻

COPY SYSTEM → **E** → *NEW SYS NAME*

Enter a name for the copied system, then press **E**.

Group-Level Settings

The settings in this section apply to all of the channels stored in the current group.

Entering/Editing the Group Name

Menu → *PROGRAM SYSTEM* → **E** ↻

Select the system → **E** ↻

EDIT GROUP → **E** ↻

Select the group → **E**

EDIT NAME → **E**

Follow these steps to enter/edit the group name.

1. Rotate the scroll control to select the first letter.
2. Press and hold down **[Func]** then rotate the scroll control once to select the next letter.
3. Repeat Steps 1 and 2 until you have entered the system name. Then press **E** or press down on the scroll control to accept the setting.

Hints:

- Each group name can be up to 16 characters. Abbreviate as necessary to fit.
- The group and system name alternate in the top line of the display when the scanner stops on a channel.
- Press **•** twice to delete the current character.
- Press **•** three times to clear the entire alpha tag.

Setting the Group Quick Key

[Menu] → *PROGRAM SYSTEM* → **E** ↻

Select the system → **E** ↻

EDIT GROUP → **E** ↻

Select the group → **E** ↻

SET QUICK KEY → **E**

After selecting this option, press **0-9** to assign the group to a quick key or press **No** to assign the system to no quick key, then press **E**.

Hints:

- You can assign as many groups to the same quick key as you want.
- To be scanned, a group's quick key must be activated.

Setting Group Lockout

Menu → PROGRAM SYSTEM → E ↻

Select the system → E ↻

EDIT GROUP → E ↻

Select the group → E ↻

SET LOCKOUT → E

This setting determines whether the scanner will scan this group when it is enabled. Select your setting, then press **E**.

LOCKOUT - the group is not scanned.

UNLOCKED - the group is scanned.

Note: The default setting is Unlocked.

Deleting Groups

Menu → PROGRAM SYSTEM → E ↻

Select the system → E ↻

EDIT GROUP → E ↻

Select the group → E ↻

DELETE GROUP → E

The scanner prompts you to confirm deletion. To confirm, press **E**. To cancel, press **No**.

Note: Deleted groups cannot be restored. You must re-enter them.

Channel-Level Settings

These settings affect only the channel you are programming.

Editing the Channel Name (Conventional Systems Only)

Menu → PROGRAM SYSTEM → E ↻

Select the system → E ↻

EDIT GROUP → E ↻

Select the group → E ↻

EDIT CHANNEL → E ↻

Programming/Editing Optional Settings

Select the channel → **E**

EDIT NAME → **E**

Follow these steps to enter/edit the channel name.

1. Rotate the scroll control to select the first letter.
2. Press and hold down **[Func]** then rotate the scroll control once to select the next letter.
3. Repeat Steps 1 and 2 until you have entered the channel name. Then press **E** or press down on the scroll control to accept the setting.

Hints:

- Each channel name can be up to 16 characters. Abbreviate as necessary to fit.
- The channel name appears on the second line of the display when the scanner stops on a channel.
- If you do not enter a channel name, the scanner displays the frequency when it stops on a channel.
- Press • twice to delete the current character.
- Press • three times to clear the entire alpha tag.
- Channel names take up extra memory. To maximize channels, use channel names only where necessary.

Setting Channel Priority

[Menu] → *PROGRAM SYSTEM* → **E** ↻

Select the system → **E** ↻

EDIT GROUP → **E** ↻

Select the group → **E** ↻

EDIT CHANNEL → **E** ↻

Select the channel → **E** ↻

SET PRIORITY → **E**

This setting controls whether the scanner treats the channel as a priority channel while scanning. Select your setting, then press **E**.

ON - when you turn on the Priority feature, the channel will be scanned every 2 seconds. *P* appears at the end of the default name.

OFF - the channel will not be treated with priority.

Note: The default setting is *OFF*.

Setting Channel Alert

Menu → PROGRAM SYSTEM → **E** ↻

Select the system → **E** ↻

EDIT GROUP → **E** ↻

Select the group → **E** ↻

EDIT CHANNEL → **E** ↻

Select the channel → **E** ↻

SET ALERT → **E**

This setting controls whether the scanner will alert you when the channel becomes active. Select your setting, then press **E**.

ON - the scanner beeps when the channel becomes active.

OFF - no alert sounds.

Note: The default setting is *OFF*.

Setting CTCSS/DCS

Menu → PROGRAM SYSTEM → **E** ↻

Select the system → **E** ↻

EDIT GROUP → **E** ↻

Select the group → **E** ↻

EDIT CHANNEL → **E** ↻

Select the channel → **E** ↻

SET CTCSS/DCS → **E**

This setting controls how a subaudible CTCSS or DCS is used for the channel. Select your setting, then press **E**.

OFF - any signal opens squelch.

Programming/Editing Optional Settings

SEARCH - the scanner searches for and displays any CTCSS or DCS tone that accompanies the transmission.

CTCSS - the scanner only opens squelch if the CTCSS tone you select is also present with the signal. The scanner then prompts you to enter or scroll to the desired tone.

DCS - the scanner only opens squelch if the DCS tone you select is also present with the signal. The scanner then prompts you to enter or scroll to the desired tone.

SET LOCKOUT - the scanner does not stop on the channel if the tone you select is present. The scanner prompts you to select a CTCSS or DCS tone.

Notes:

- The default setting is *OFF*.
- See “What is CTCSS/DCS?” on Page 17 for a complete list of CTCSS and DCS tones.

Setting Channel Modulation

Menu → *PROGRAM SYSTEM* → **E** ↻

Select the system → **E** ↻

EDIT GROUP → **E** ↻

Select the group → **E** ↻

EDIT CHANNEL → **E** ↻

Select the channel → **E** ↻

SET MODULATION → **E**

This setting controls the demodulation method used for the channel. Select your setting, then press **E**.

AUTO - the scanner uses the default modulation for the frequency (see the table at the front of the manual).

AM - the scanner uses AM (amplitude modulation) for the frequency.

FM - the scanner uses FM (frequency modulation) for the frequency.

Programming/Editing Optional Settings

NFM - the scanner uses narrowband FM for the frequency.

Note: The default setting is *AUTO*.

Setting Channel Attenuation

Menu → PROGRAM SYSTEM → **E** ↻

Select the system → **E** ↻

EDIT GROUP → **E** ↻

Select the group → **E** ↻

EDIT CHANNEL → **E** ↻

Select the channel → **E** ↻

SET ATTENUATOR → **E**

This setting controls whether the scanner attenuates signals on this channel. Select your setting, then press **E**.

ON - the channel is attenuated by about 18 dB.

OFF - the channel is not attenuated.

Notes:

- The default setting is *OFF*.
- You can also toggle this setting by holding on the channel and pressing **Func** and **E**.

Setting the Frequency Step

Menu → PROGRAM SYSTEM → **E** ↻

Select the system → **E** ↻

EDIT GROUP → **E** ↻

Select the group → **E** ↻

EDIT CHANNEL → **E** ↻

Select the channel → **E** ↻

SET STEP → **E**

This setting selects the frequency step used for setting the channel's. Select your setting, then press **E**.

AUTO - the step is based on the band (see the table at the front of the manual)

Programming/Editing Optional Settings

5.0 KHZ, 6.25 KHZ, 7.5 KHZ, 10.0 KHZ, 12.5 KHZ, 15.0 KHZ,
20.0 KHZ, 25.0 KHZ, 50.0 KHZ, 100.0 KHZ - The scanner
uses the selected step.

Note: The scanner defaults to *AUTO*.

Setting Channel Lockout

Menu → *PROGRAM SYSTEM* → **E** ↻

Select the system → **E** ↻

EDIT GROUP → **E** ↻

Select the group → **E** ↻

EDIT CHANNEL → **E** ↻

Select the channel → **E** ↻

SET LOCKOUT → **E**

This setting determines whether the scanner will scan this channel when its system and group are enabled. Select your setting, then press **E**.

LOCKOUT - the channel is not scanned.

UNLOCKED - the channel is scanned.

Notes:

- The default setting is Unlocked.
- You can also lock or unlock a channel by selecting it while scanning or holding, then pressing **L/O**. See “Basic Operation” on Page 34.

Deleting Channels

Menu → *PROGRAM SYSTEM* → **E** ↻

Select the system → **E** ↻

EDIT GROUP → **E** ↻

Select the group → **E** ↻

EDIT CHANNEL → **E** ↻

Select the channel → **E** ↻

DELETE CHANNEL → **E**

Programming/Editing Optional Settings

The scanner prompts you to confirm deletion. To confirm, press **E**. To cancel, press **No**.

Note: Deleted channels cannot be restored. You must re-enter them.

Copying/Pasting Channels

To copy a channel including all settings:

Menu → PROGRAM SYSTEM → **E** ↻

Select the system → **E** ↻

EDIT GROUP → **E** ↻

Select the group → **E**

EDIT CHANNEL → **E** ↻

Select the channel → **E**

COPY CHANNEL → **E**

The scanner copies the channel into a copy buffer.

To paste the channel into the same or another system:

Menu → PROGRAM SYSTEM → **E** ↻

Select the system → **E** ↻

EDIT GROUP → **E** ↻

Select the group → **E**

EDIT CHANNEL → **E** ↻

PASTE CHANNEL → **E**

Then, if necessary, edit the channel you copied to give it a unique name and other settings.

Note: The paste option appears only if you have previously copied a channel from a system of the same type you are currently editing.

Searching and Storing

Service Search

Service Search lets you quickly select and search the scanner's preprogrammed search ranges. During service search, the scanner searches starting with the lowest frequency in the search range you select to the highest frequency in the range.

1. Press **Menu** then turn the scroll control until *SEARCH FOR . . .* appears. Then press **E**. Or press **Func** and **Srch**, then **No**. The search feature options appear.
2. Turn the scroll control until *SERVICE SEARCH* appears, then press **E** to select it.
3. Turn the scroll control until the type of service search you want appears, then press **E** to select it.

The following search bands appear.

*PUBLIC SAFETY
NEWS
HAM RADIO
MARINE
RAILROAD
AIR
CB RADIO
FRS/GMRS
RACING
SPECIAL*

The scanner searches the service you selected, stopping on any transmission it finds and displaying the frequency. Turn the scroll control to change the search direction. An arrow appears, showing the current search direction.

To hold searching, press **Hold**. To resume searching, press **Func** then press **Scan/Srch**. Or, press **Hold**.

To lock out a frequency found while searching, press **L/O**. *SEARCH LOCKOUT?* appears. Press **E** to lock out the frequency or **No** to continue monitoring.

Notes:

- If all frequencies in the search band you selected are locked out, *ALL LOCKED!* appears and the scanner does not search the band.

Searching and Storing

-
-
- If the service you select uses channels (such as CB radio or marine), the scanner displays the service channel number.

Quick Search

Quick Search lets you search from the currently-tuned frequency.

Press **Func** and **Scan/Srch** to start quick search. *QUICK SEARCH?* appears. *QUICK SEARCH HOLD* appears if you press **Hold**. Press **E** to start quick search or **No** to go to the search menu.

CTCSS/DCS Search

CTCSS/DCS Search lets you search for CTCSS or DCS tones when it finds an active frequency in search and Close Call modes. You can identify up to 50 CTCSS tones and 104 DCS codes.

Turning this option on lets the scanner search for CTCSS/DCS tones. If the scanner detects the tone, it displays the tone's frequency and DCS code.

1. Press **Menu** then turn the scroll control until *SRCH/CLOCALL OPT* appears. Then press **E**. One of the search feature options appear.
2. Turn the scroll control until *CTCSS/DCS SEARCH* appears, then press **E** to select it.
3. Turn the scroll control until *ON* appears to turn on CTCSS/DCS search or until *OFF* appears to turn it off, then press **E**.

Custom Search

Custom Search lets you program and search 10 custom search ranges. You can search any of these ranges simultaneously and select each custom search range you set. During custom search, the scanner searches starting with the lowest frequency in the search range you select to the highest frequency in the range.

Searching and Storing

Notes:

- Search ranges are preset. See “Editing a Custom Search Range” on Page 69 to change the range.
 - You cannot turn off all custom search ranges.
1. Press **Menu** then turn the scroll control until *SEARCH FOR ...* appears. Or, press **Func** + **Scan/Srch**, then select **No**, then turn the scroll control, then press **E**. One of the search feature options appear.
 2. Turn the scroll control until *CUSTOM SEARCH* appears, then press **E** to select it. The scanner starts custom search of the custom search range you selected, stopping on any transmission it finds and displaying the frequency. Turn the scroll control to change the search direction. An arrow appears, showing the current search direction.

To turn search ranges on or off, press **0** and **1-9**.

To hold searching, press **Hold**. To resume searching, press **Func** then press **Scan/Srch** or **Hold** again.

To lock out a frequency found while searching, press **L/O**. *SEARCH LOCKOUT?* appears. Press **E** to lock out the frequency or **No** to continue monitoring.

If you turn off the active custom search range, the scanner skips to the next custom search range and continues searching.

Note: If all frequencies in all active custom search ranges are locked out, *ALL LOCKED!* appears and the scanner does not stop.

Editing a Custom Search Range

You can edit up to 10 custom search ranges. The names of the custom search ranges appear on the display. The default custom search range names appear as *CUSTOM 1*, *CUSTOM 2*, and so on.

1. Press **Menu** then turn the scroll control until *SEARCH FOR ...* appears. Then press **E**. Or press **Func**

and **Srch**, then **No**. One of the search feature options appear.

2. Turn the scroll control until *EDIT CUSTOM* appears, then press **E** to select it.
3. Turn the scroll control until the name of the custom search range you want to edit appears, then press **E** to select it. The following options appear as you turn the scroll control.

EDIT NAME - lets you edit the custom search range's name

EDIT SRCH LIMIT - lets you view and select the frequency ranges to search. The scanner prompts you to enter the upper and lower search limits.

SET DELAY TIME - lets you set the amount of time the scanner will delay before continuing to search after a transmission ends

SET MODULATION - lets you set the custom search range's modulation type

SET ATTENUATOR - lets you set whether the scanner will attenuate reception by 18dB during search

SET DATA SKIP - lets you set whether the scanner will skip data transmissions during search

SET STEP - lets you set the custom search range's step (the gap between frequencies)

4. Select the option you want to change for the custom search range you selected, then press **E**.

Auto Search and Store

Your scanner's Auto Store feature lets you search for new frequencies in custom search ranges or within a service search range.

Selecting a System

To store frequencies you find during Auto Store, you must first select a system where the frequencies will be stored.

1. Press **Menu** then turn the scroll control until *SEARCH FOR ...* appears. Then press **E**. One of the search feature options appear.

Searching and Storing

-
-
2. Turn the scroll control until *SEARCH AND STORE* appears, then press **E** to select it.
 3. Turn the scroll control until the system where you want to store the frequencies appears, then press **E** to select it.

Note: You cannot select a racing system.

If no systems are programmed, or all systems are locked out, *NO SYSTEM STORED* appears.

Storing a System

You can store frequencies into the system you selected in “Selecting a System”. Otherwise, the scanner stores frequencies in a new group it creates.



1. Follow Steps 1-3 under “Selecting a System”.
A search option appears.
2. Turn the scroll control until the type of search you want appears, then press **E** to select it. A search band appears.

If all systems are locked out, *ALL LOCKED!* appears and the scanner does not store any frequencies.

When you select a search range, the scanner looks for active frequencies within that range and *SEARCH AND STORE* appears on the display’s lower line and the system name and search range name appear on the display’s upper line. When the scanner finds an active transmission, it checks to see if the frequency has already been stored in the system. If the frequency has already been stored, the scanner continues to search. If the frequency has not been stored, it stores the frequency into a group named *FOUND CHANNELS*, then resumes searching. The scanner creates this group if it does not already exist.

Using the Close Call Feature

Your scanner's Close Call™ feature lets you set the scanner so it detects, displays the frequency of, and lets you hear a nearby strong radio transmission. You can set the scanner so the Close Call feature works "in the background" while you are scanning other frequencies, turn off normal scanning while the Close Call feature is working, or turn off the Close Call feature and use the scanner normally. You can set the scanner so it alerts you when the Close Call feature finds a frequency. You can also set the frequency band where you want the scanner to look for transmissions.

To turn Close Call detection on or off, press **[Func]** then . When the feature is on,  appears on the display and normal operation is briefly interrupted about every 2 seconds.

Notes:

- The Close Call feature works well for locating the source of strong local transmissions such as mobile and handheld two-way radios in areas with no other strong transmission sources. Several factors affect Close Call performance, however. Performance is increased with higher transmit power, receive antenna tuned to the target band, and a low background RF level. Other than the antenna, you have no control over these factors, but they explain why performance might vary by both location and time.
- The Close Call feature cannot detect satellite dishes or any transmitter with a frequency above or below the frequency ranges listed under "Setting Close Call Options" on Page 73.
- The Close Call feature works better with some types of transmissions than others. It might not correctly display frequency information for transmitters using a highly directional antenna (such as an amateur radio beam antenna) or if there are many transmitters operating at the same time in the same area.

Setting Close Call Options

1. Press **Menu** then turn the scroll control until *CLOSE CALL* appears. Then press **E**. Close Call feature options appear.
2. Turn the scroll control to select an option.

- *CLOSE CALL ONLY*: Lets you set the scanner only for Close Call searching. The scanner does not scan frequencies or channels when this option is turned on.

To select this option, press **E**.

- *SET CC BANDS*: Lets you select the Close Call band settings. You can turn the following bands on or off.

VHF LOW (25.0000 - 54.0000 MHz)

AIR BAND (108.0000 - 136.9750 MHz)

VHF HIGH (137.0000 - 224.9800 MHz)

UHF (400.0000 - 512.0000 MHz)

800MHz+ (806.0000 - 956.0000 MHz)

Use the scroll control to select a band, press **E**, then use the scroll control to select *ON* or *OFF* and press **E**. Turning off undesired bands speeds up Close Call operation. (The Close Call feature does not work for frequencies greater than 956 MHz.)

- *SET CC ALERT*: Lets you select how the scanner alerts you when it receives a Close Call signal. You can select any of the following options.

*BEEP*LIGHT* (the scanner beeps and the backlight turns on when it receives a Close Call signal)

LIGHT (the backlight turns on when it receives a Close Call signal)

BEEP (the scanner beeps when it receives a Close Call signal)

NONE (the scanner does not alert)

Turn the scroll control to display an option, then press **E**.

- *SET CC OVERRIDE*: Lets you select how the Close Call feature works with other scanning activities. If you turn this option off, when the scanner detects a Close Call signal, *CC FOUND!* and *E TO LISTEN* appear for about 3 seconds. Press **E** when this appears to jump to and hold on the frequency.

Using the Close Call Feature

If this option is turned on, the scanner overrides the current channel and goes to the Close Call hit. The scanner displays *CC FOUND! PRESS ANY KEY*. When you press a key, the frequency is displayed.

Turn the scroll control to display an option, then press **E**.

- *SET CC MODE*: Lets you select the Close Call mode. If you turn this option on, the scanner sets itself to its Close Call settings about once every 2 seconds. Turn the scroll control to display an option, then press **E**.

You can also toggle this setting by pressing **Func** then .

- *CC AUTOSTORE*: Lets you select whether the scanner automatically stores Close Call hits into channels. If you turn this option on, the scanner starts Close Call mode and stores any Close Call hits, up to the maximum you specified in the Max Auto Store setting. If the scanner stores more hits than this setting, it stops Autostore operation.

Turn the scroll control to display an option, then press **E**.

Close Call Hits

When the scanner detects a Close Call hit, it alerts you according to the Override and Alert settings in the previous section. While listening to a Close Call hit, you can press **Hold** to hold on the hit frequency, press **E** to quickly save the frequency into memory, press **L/O** to lock out the frequency from Close Call and Search operation, or wait for the transmission to end. If you are in Close Call Only or Close Call Override mode, and you do not press any key, the scanner returns to its previous operation after the transmission ends and the set delay time expires.

If you are holding on the frequency, press **Hold** again to resume the previous operation.

Search and Close Call Options

The settings in this section affect custom searches, service searches, and Close Call operation.

Managing Locked-Out Frequencies

While searching or during Close Call operation, if you press **L/O** while the scanner is stopped on a frequency, that frequency is locked out of these modes. You can lock out up to 200 frequencies.

Note: Locking out a frequency does not lock out a channel that contains that frequency.

Unlocking All Frequencies

Menu → **↻** *SRCH/CLOCALL OPT* → **E** **↻**
FREQ LOCKOUTS → **E** **↻** → *UNLOCK ALL* → **E**

The scanner prompts you to confirm deletion. To confirm and delete all locked-out frequencies, press **E**. Otherwise, to cancel, press **No**.

Reviewing Locked Out Frequencies

Menu → **↻** *SRCH/CLOCALL OPT* → **E** **↻**
FREQ LOCKOUTS → **E** **↻** → *RVW SEARCH L/O* → **E**

The scanner displays the first locked-out frequency and prompts you to unlock the frequency. Press **E** to unlock the frequency. Or, rotate the scroll control or press **No** to select a different frequency. To exit the review, press

Menu.

Searching for Subaudible Tones

Menu → **↻** *SRCH/CLOCALL OPT* → **E** **↻**
CTCSS/DCS SEARCH → **E**

This setting controls whether the scanner will search for a subaudible tone when it stops on a transmission during search or Close Call operation.

OFF The scanner does not search for subaudible tones.

ON The scanner searches for and displays any subaudible tone found.

Search and Close Call Options

Note: This feature does not operate when the scanner is in AM modulation mode.

Screening Out Paging Systems

Menu → ↻ SRCH/CLOCALL OPT → E ↻
PAGER SCREEN → E

This setting determines whether the scanner automatically ignores transmissions found during searching or Close Call operation that are on common paging system frequencies.

ON The scanner skips known paging system frequencies.

OFF The scanner stops on any detected transmission, including paging systems.

Notes:

- The default setting for this feature is *ON*.
- The frequencies include paging systems and also the NOAA weather frequencies.
- Even with the feature on, you might hear some paging systems. Some frequencies are shared between business radio systems and paging systems. If the scanner stops on a paging system even with this feature turned on, manually lock it out by pressing **L/O**.

Finding Repeater Output Frequencies

Menu → ↻ SRCH/CLOCALL OPT → E ↻
REPEATER FIND → E

This feature sets whether the scanner tries to tune to a repeater output frequency during Close Call operation when it detects a transmission on a repeater input frequency. Since you can normally only hear one side of a conversation when you listen to an input frequency transmission, turning this feature on can let you hear both sides of the conversation.

Search and Close Call Options

ON The scanner automatically applies repeater reverse to detected transmissions. If the scanner detects the transmission on the output frequency, it beeps, *REPEATER FIND* appears, and it remains on the output frequency until transmissions end. If it does not detect a transmission on the output frequency, it remains on the original frequency.

OFF The scanner does not try to find the output frequency.

Setting the Maximum Auto Store Value

Menu → ↻ *SRCH/CLOCALL OPT* → **E** ↻
MAX AUTO STORE → **E**

This value sets how many hits the scanner will automatically store when it is in either Search and Store or Close Call Auto Store mode.

Use the number keys to enter a value from 1 - 256, then press **E**.

When the scanner reaches the maximum number of hits you set, it stops the auto-store operation.

Setting the Modulation Type

Menu → ↻ *SRCH/CLOCALL OPT* → **E** ↻
SET MODULATION → **E**

This setting controls the modulation type used for quick search and Close Call operations. Select your setting, then press **E**.

AUTO Uses the default setting for the current frequency (see the table at the front of the manual)

AM Uses AM (amplitude modulation)

FM Uses FM (frequency modulation)

NFM Uses narrowband FM

Setting Attenuation

Menu → ↻ SRCH/CLOCCALL OPT → **E** ↻
SET ATTENUATOR → **E**

This setting controls the attenuator for quick search and Close Call operation. Select your setting, then press **E**.

OFF The attenuator is off.

ON Reception is attenuated by about 18 dB.

Note: Turn on this setting if you are near other strong signal sources. Attenuation sometimes helps to reduce interference and desensitization that strong signals create.

Setting Data Skip

Menu → ↻ SRCH/CLOCCALL OPT → **E** ↻
SET DATA SKIP → **E**

This setting controls how the scanner behaves when it detects a constant-level transmission during quick search or Close Call operation. Select your setting, then press **E**.

OFF The scanner remains on the transmission until it ends.

ON The scanner quickly resumes searching or Close Call operation.

Notes:

- If you are trying to test the Close Call feature with a nearby transmitter and you do not talk into the transmitter, the scanner will detect this as data and will skip the frequency when Data Skip is on. Turn the feature off or talk into the transmitter.
- The default for this feature is *ON*.

Setting the Delay Time

Menu → ↻ SRCH/CLOCCALL OPT → **E** ↻
SET DELAY TIME → **E**

This setting determines how long the scanner waits after a transmission ends before resuming quick search or Close Call operation. Select your setting, then press **E**.

Search and Close Call Options

OFF The scanner resumes immediately when the transmission ends.

1-5 SEC The scanner waits the set amount of time after the transmission ends before resuming.

Note: The default setting is 2 seconds.

Setting the Search Frequency Step

Menu → ↻ *SRCH/CLOCALL OPT* → **E** ↻
SET STEP → **E**

This setting selects the frequency step used for setting the channels. Select your setting, then press **E**.

AUTO The step is based on the band (see the table at the front of the manual)

5.0 KHZ, 6.25 KHZ, 7.5 KHZ, 10.0 KHZ, 12.5 KHZ, 15.0 KHZ, 20.0 KHZ, 25.0 KHZ, 50.0 KHZ, 100.0 KHZ The scanner uses the selected step.

Note: The scanner defaults to *AUTO*.

Using Weather Alert (SAME)

Your scanner has been primarily designed to be a radio scanner. While it incorporates weather alert as one of its features, we strongly recommend that you not use the scanner as your sole means for receiving emergency alerts. Your local electronics retailer carries several weather radios specifically designed for this function.

Your scanner allows you to search for a local NOAA weather broadcast and set it to alert when a SAME weather alert is broadcast on a NOAA channel. You can also program SAME codes into the scanner and set a weather channel as a priority channel.

In the following sections, you can also access the weather menu from Hold mode by holding **[Func]** then pressing **Wx**.

Searching For a Weather Broadcast

[Menu] → ↻ *LWX OPERATION* → **E** →
WEATHER SCAN → **E**

The scanner starts scanning the preprogrammed weather frequencies, and stops on the first signal. If this station is weak, rotate the scroll control to check for other weather broadcasts in your area.

Note: NOAA broadcasts are continuous broadcasts. You will only lose reception if you move out of a coverage area. If the signal is lost, the scanner resumes searching for a weather transmission.

Turning Weather Alert On/Off

In weather alert mode, your scanner functions as a severe weather warning radio. This is especially useful when your area is expecting severe weather conditions late at night. When you set the scanner to weather alert mode, it holds on the weather channel, but does not play the channel's audio. If it detects a weather alert, it sounds a tone, displays information about the weather alert, and turns on the audio so you can hear the weather broadcast.

[Menu] → ↻ *LWX OPERATION* → **E** ↻
WEATHER ALERT → **E**

Using Weather Alert (SAME)

This setting determines which types of signals will trigger an alert. Select your setting, then press **E**.

ALERT ONLY - the scanner alerts when it detects the 1050 Hz tone that accompanies all weather alerts.

ALL FIPS - the scanner alerts and displays information about the weather alert when it receives any FIPS code (see “Programming a SAME Group” on Page 81).

SAME 1-5 - the scanner alerts and displays information about the weather alert when it receives a weather alert signal that includes any FIPS code you have programmed into the specified SAME group.

Programming a SAME Group

You can edit any of the 5 SAME groups in your scanner. Each group can have up to 8 FIPS codes.

SAME (Specific Area Messaging System) is a system developed by the National Weather Service to reduce the number of alerts received by consumers by allowing them to hear alerts only for the county(ies) they are interested in. Each alert contains information about the type and severity of the alert, as well as the specific geographic locations affected by the alert.

The geographic locations are designated using FIPS codes. Each county or parish in the US and its territories are assigned a FIPS code. In addition, certain special regions and wildcard settings can be assigned.

FIPS codes are in the format nSSCCC:

n: A special subcounty designator. For an entire county, use 0.

SS: The state code.

CCC: The county code.

Using Weather Alert (SAME)

For example, Tarrant County in Texas is assigned to FIPS code 048439.

0 indicates the entire county

48 indicates the state of Texas

439 indicates Tarrant County

To get the FIPS code for your county, visit the National Weather Service web site at <http://www.nws.noaa.gov> and search for “FIPS Listing”.

Menu → ↻ *LUX OPERATION* → **E** ↻
PROGRAM SAME → **E** ↻ *SELECT SAME* →
↻ select the SAME group to edit → **E**

Select the setting to change, then press **E**.

EDIT NAME - enter the name you want to assign to the SAME group you selected (see “Entering Text” on Page 15).

EDIT COUNTY - select the position you want to store the FIPS code into, then press **E**, enter the FIPS code, and press **E** again.

Setting WX Alert Priority

Menu → ↻ *LUX OPERATION* → **E** ↻
LUX ALT PRIORITY → **E**

ON - the scanner checks the weather channels every 5 seconds for a 1050 Hz weather alert signal. Press **E** to select.

OFF - the scanner does not check the weather channels. Press **E** to select.

Using Weather Alert (SAME)

Care and Maintenance

General Use

- Turn the scanner off before disconnecting the power.
- Always write down the programmed frequencies in the event of memory loss.
- If memory is lost, simply reprogram each channel.
- Always press each button firmly until you hear the entry tone for that key entry.

Location

- Do not use the scanner in high-moisture environments such as the kitchen or bathroom.
- Avoid placing the unit in direct sunlight or near heating elements or vents.
- If the scanner receives strong interference or electrical noise, move it or its antenna away from the source of the noise. If possible, a higher elevation might provide better reception.
- Also try changing the height or angle of the antenna.

Cleaning

- Disconnect the power to the unit before cleaning.
- Clean the outside of the scanner with a mild detergent.
- To prevent scratches, do not use abrasive cleaners or solvents. Be careful not to rub the LCD window.
- Do not use excessive amounts of water.

Repairs

Do not attempt any repair. The scanner contains no user serviceable parts. Contact the Uniden Customer Service Center or take it to a qualified repair technician.

Birdies

All radios can receive “birdies” (undesired signals). If your scanner stops during Scan mode and no sound is heard, it might be receiving a birdie. Birdies are internally generated signals inherent in the electronics of the scanner.

Press **L/O** to lock out the channel.

Troubleshooting

If your SC230 is not performing properly, try these steps.

Problem	Possible Cause	Suggestion
The scanner doesn't work.	The scanner might not be receiving any power.	Make sure the AC adapter is connected to an AC outlet and the scanner.
		If there is a wall switch that controls power to the AC outlet where you connected the AC adapter, make sure it is on.
Improper reception.	The antenna might need to be adjusted.	Check the antenna connection or move or reposition the antenna.
		Move the scanner.
		You might be in a remote area that could require an optional multi-band antenna. Check with your dealer or local electronics store.
Scan won't stop.	The squelch might need to be adjusted.	Adjust the squelch threshold. See "Turning On the Scanner and Setting the Squelch" on Page 34.
	The antenna might need to be adjusted.	Check the antenna connection.
	One or more channels might be locked out.	Make sure the channels you want to scan are not locked out.
	The channel's frequency might not be stored in memory.	Make sure the channel's frequency is stored in the scanner's memory.
	The channel might not be active.	Wait for a transmission on the channel.

Troubleshooting

Scan won't start.	You must press Scan to scan.	Press Scan .
	The squelch might need to be adjusted.	Adjust the squelch threshold. See "Turning On the Scanner and Setting the Squelch" on Page 34.
	One or more channels might be locked out.	Make sure the channels you want to scan are not locked out.
	The antenna might need to be adjusted.	Check the antenna connection.
Weather scan doesn't work.	The squelch might need to be adjusted.	Adjust the squelch threshold. See "Turning On the Scanner and Setting the Squelch" on Page 34.
	The antenna might need to be adjusted.	Check the antenna connection.
	There might not be a NOAA weather broadcast in your area.	Move to an area with a NOAA weather broadcast.

If you still cannot get satisfactory results while using your scanner or if you want additional information, please call or write the Uniden Parts and Service Division. The address and phone number are listed in the Warranty at the end of this manual. If you would like immediate assistance, please call Customer Service at (800) 297-1023.

If you have Internet access, you can visit <http://www.uniden.com> for additional information.

Troubleshooting

Specifications

Certified in accordance with FCC Rules and Regulations
Part 15, Subpart C, as of date of manufacture.

Dynamic Allocation Capacity
(with Name Assigned To Each System, Group, and
Channel):

Systems: 200 max

Groups:

Conventional Systems 20 per system

Racing Systems No Limit

Channels: up to 2500

Attenuation: 18 dB (nominal), 10 dB (limit)

Frequency Range (MHz):

25.0 - 26.960 Petroleum Prods/Bcst Pickup Band

26.965 - 27.405Citizens Band Class D

27.410 - 27.995Business/Forest Prods

144.0 - 147.995 2 Meter Amateur Band

150.8 - 161.995 VHF High Band

Above bands in 5 kHz steps

29.7 - 49.990 VHF Low Band

Above band in 10 kHz steps

137.0 - 143.9875 Military Band

148.0 - 150.7875Military Band

162.0 - 174.0 Federal Government

400.0 - 405.9875Miscellaneous

406.0 - 419.9875 Federal Land Mobile

420.0 - 449.9875 70 cm Amateur Band

450.0 - 469.9875 UHF Standard Band

470.0 - 512.0 UHF TV Band

806.0 - 823.9875 Public Service Band

849.0125 - 868.9875 Public Service Band

894.0125 - 956.0 Public Service Band

Above bands in 12.5 kHz steps

28.0 - 29.680 10 Meter Amateur Band

50.0 - 54.0 6 Meter Amateur Band

216.0 - 224.980 1.25 Meter Amateur Band

Above bands in 20 kHz steps

108.0 - 136.9750Aircraft

1240.0 - 1300.0 25 cm Amateur Band

Above bands in 25 kHz steps

Specifications

Operating Temperature:

Normal -20°C to +60°C
Close Call -10°C to +60°C

Scan Rate: 100 channels per second
(conventional mode)

Search Rate: 300 steps per second (5 kHz step only)

Scan Delay: 0-5 seconds

Audio Output: .. 320mW nominal into 8Ω internal speaker
30 mW nominal into 32Ω headphone
6 mW nominal into 64Ω earphone

Power Requirements:

2 AA Alkaline Batteries (3V DC),
or 2 AA Rechargeable Ni-MH Batteries (2.4V DC),
or AC Adapter (6 VDC 500mA) (AD-1017)
(AC adapter AD-0008 [discontinued] can also be used.)

Antenna: 50 Ω (Impedance)

External Jacks:

Antenna Jack BNC Type
Headphone Jack 3.5mm
DC Power Jack (EIAJ TYPE-2 Center Positive) 5.5mm
Remote Jack 4 Pin Mini

Size: 2.9 in. (W) x 1.4 in. (D) x 4.6 in. (H)

Weight: 0.49 lbs

Features, specifications, and availability of optional accessories are all subject to change without notice.

Specifications

Optional Accessories

Contact your local Uniden Dealer or call the Uniden Parts Center at: (800) 554-3988 during regular business hours (CST) for information about ordering these optional accessories.

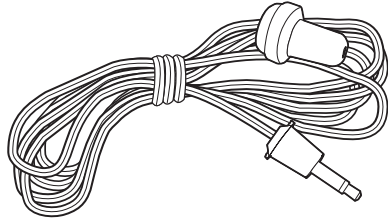

Earphone

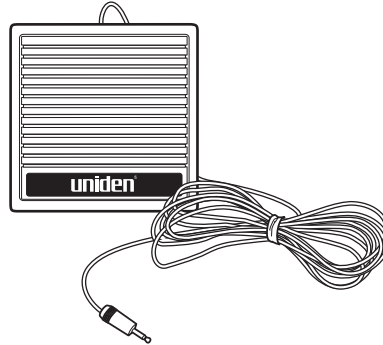

External Amplified Speaker



Betty Bearcat Frequency Directory/
Local Directories

Planning

Collecting Information

Getting your scanner programmed and scanning takes a few steps. This help guides you through these steps that will make it easier for you to start scanning.

1. Collect information about the system(s) you want to monitor.

Do you want to listen to your favorite driver at the track? How about your local police and fire departments, the highway patrol, ambulance service, and aircraft? You might even want to listen to race officials as they dispatch the pace car.

Make a list of the drivers, tracks, and agencies you want to listen to, then look up the frequencies and systems they use. The Internet is a great source for current frequencies and information about scanning. Here are a few useful sites:

- <http://www.scannermaster.com/> - frequency resources and home of Police Call.
You can also call them at 1 800 SCANNER (hours are from 10:00 a.m. to 5:00 p.m. Eastern Time Monday through Friday.)
- <http://www.radioreference.com/> - the Internet's premier source for user-supported radio system information.
- <http://www.bearcat1.com/> - frequency information from National Communications.
- <http://svartifoss2.fcc.gov/reports/index.cfm> - conventional frequency information on file with the US Government

Tips:

- Scanners are designed to monitor complex radio systems. That means that programming your scanner might seem like a daunting task at first. Be patient if you don't get it right the first time. You can also seek out help locally for the systems you want to scan by visiting the forums section of <http://www.radioreference.com/modules.php?name=Forums>.

-
-
- Before you start to program your scanner, decide how you want to organize the frequencies you want to scan. For example, some areas are best organized by geographic location (east, north, south, west, central, etc), while others are best organized by agency (police, sheriff, ambulance, fire, etc.). You might even find it easier to organize a mixture of frequencies (north, southeast, and west for police but fire all in one group for example).
 2. Organize the system information using these system worksheets included in this appendix.
 - Use “Racing System Worksheet” on Page 93 to organize info about racing frequencies.
 - Use “Conventional System Worksheet” on Page 95 to organize info about conventional frequencies.
 3. Follow the instructions in “Filling Out The Racing System Worksheet” on Page 92 and “Filling Out The Conventional System Worksheet” on Page 94 to program your scanner.

Tips:

- Before you start, make as many copies of the worksheets as you think you'll need. You can also go to the download section of <http://www.uniden.com/productsupport.cfm> and download the worksheets there.
- All worksheet instructions assume that you have completed the critical Step 1 (collecting the system information). Don't skip this step.
- Use a pencil to fill out the worksheets. This lets you change information if necessary.

Filling Out The Racing System Worksheet

Race Name

Fill in the name of the race you want to scan. For example, you can enter "Daytona 500" here.

Car #/Driver-Frequency-Priority-CTCSS/DCS

Fill in the details for each car number and driver, frequency, whether the car number/driver is a priority car number/driver, and information about the car number/driver's CTCSS/DCS information (if any) you want to store for this race.

Filling Out The Conventional System Worksheet

System Name and Quick Key

Fill in a name that describes the system you want to create. For example, you can enter "Dallas Police" or "Amateur Radio" here. If you want to store more than one type of frequency, you can enter "Mixed."

Fill in the key you want to press to quickly activate/deactivate the system. You can assign the same quick key to multiple systems.

Group Name and Quick Key

Each worksheet documents the settings for one channel group within a system. If you have fewer channels in the group than fits on the page, you can skip a line and enter an additional group of channels (enter the group info in the line you skipped). If you have more channels for the group than will fit on the page, use additional pages.

Fill in the key you want to press with **Func** to quickly activate/deactivate the channel group. You can assign the same quick key to multiple groups within a system.

Frequency-Alpha Tag-Priority-CTCSS/DCS

Fill in the details for each channel you want to store in this channel group.

Preprogrammed Systems

Your scanner is preprogrammed with frequencies used at races within the NASCAR Nextel, Busch, Craftsman, Indy, ARCA, and Champ racing series. One racing system and one conventional system are preprogrammed for each race.

By default, all of the preprogrammed conventional systems and one of the racing systems are unlocked, and your scanner begins to scan them when you turn it on. To speed up scanning, you can lock out systems that are beyond your reception area (typically no more than a few miles using the supplied stub antenna).

Follow these steps to lock out systems:

1. Press and hold **[Func]**.
2. While continuing to hold **[Func]**, rotate the scroll control to select a system you want to lock out.
3. While continuing to hold **[Func]**, press **L/O** to lock out the system.
4. Repeat Steps 2, 3, and 4 to lock out additional systems.

The preprogrammed systems provide a starting point; you will want to find out more information about your local radio systems so you can customize the programming to better suit your listening preferences.

Notes:

- You might hear transmissions on frequencies assigned to very distant stations. This will happen if a local system also uses the same frequency. Disregard the text tag for these transmissions (e.g. if you are in California, you aren't really receiving Florida transmissions even if the scanner displays *DADE COUNTY*).
- To free up memory, you can delete systems that you will not be monitoring. Refer to "Deleting Systems" on Page 58.
- Data used for the preprogrammed information was supplied courtesy of <http://www.radioreference.com>, the Internet's premier scanning resource (RadioReference is not affiliated with Uniden America Corporation).

One-Year Limited Warranty

Important: Evidence of original purchase is required for warranty service.

WARRANTOR: UNIDEN AMERICA CORPORATION (“Uniden”)

ELEMENTS OF WARRANTY: Uniden warrants, for one year, to the original retail owner, this Uniden Product to be free from defects in materials and craftsmanship with only the limitations or exclusions set out below.

WARRANTY DURATION: This warranty to the original user shall terminate and be of no further effect 12 months after the date of original retail sale. The warranty is invalid if the Product is (A) damaged or not maintained as reasonable or necessary, (B) modified, altered, or used as part of any conversion kits, subassemblies, or any configurations not sold by Uniden, (C) improperly installed, (D) serviced or repaired by someone other than an authorized Uniden service center for a defect or malfunction covered by this warranty, (E) used in any conjunction with equipment or parts or as part of any system not manufactured by Uniden, or (F) installed or programmed by anyone other than as detailed by the Operating Guide for this product.

STATEMENT OF REMEDY: In the event that the product does not conform to this warranty at any time while this warranty is in effect, warrantor will repair the defect and return it to you without charge for parts, service, or any other cost (except shipping and handling) incurred by warrantor or its representatives in connection with the performance of this warranty. THE LIMITED WARRANTY SET FORTH ABOVE IS THE SOLE AND ENTIRE WARRANTY PERTAINING TO THE PRODUCT AND IS IN LIEU OF AND EXCLUDES ALL OTHER WARRANTIES OF ANY NATURE WHATSOEVER, WHETHER EXPRESS, IMPLIED OR ARISING BY OPERATION OF LAW, INCLUDING, BUT NOT LIMITED TO ANY IMPLIED WARRANTIES OF MERCHANTABILITY OR FITNESS FOR A PARTICULAR PURPOSE. THIS WARRANTY DOES NOT COVER OR PROVIDE FOR THE REIM-

One-Year Limited Warranty

BURSEMENT OR PAYMENT OF INCIDENTAL OR CONSEQUENTIAL DAMAGES. Some states do not allow this exclusion or limitation of incidental or consequential damages so the above limitation or exclusion might not apply to you.

LEGAL REMEDIES: This warranty gives you specific legal rights, and you might also have other rights which vary from state to state. This warranty is void outside the United States of America.

PROCEDURE FOR OBTAINING PERFORMANCE OF WARRANTY: If, after following the instructions in this Operating Guide you are certain that the Product is defective, pack the Product carefully (preferably in its original packaging). Include evidence of original purchase and a note describing the defect that has caused you to return it. The Product should be shipped freight prepaid, by traceable means, or delivered, to warrantor at:

Uniden America Corporation

Parts and Service Division

4700 Amon Carter Boulevard

Fort Worth, TX 76155

(800) 297-1023

Visit www.uniden.com for current business hours.

FOR
ACCESSORIES,
GO ONLINE &
WWW.UNIDEN.COM

REGISTER ONLINE TODAY!

THANK YOU FOR BUYING A UNIDEN PRODUCT.

A World Without Wires® **Uniden**

May be covered under one or more of the following U.S. patents.

4,398,304	4,409,688	4,455,679	4,461,036	4,521,915	4,597,104
4,627,100	4,841,302	4,888,815	4,932,074	4,947,456	5,014,348
5,139,109	5,408,892	5,428,826	5,438,888	5,448,256	5,485,402
5,471,680	5,483,684	5,530,296	5,548,832	5,571,071	5,574,995
5,577,076	5,598,430	5,600,223	5,642,424	5,710,992	5,859,875
5,896,422	5,991,346	5,991,603	6,012,158	6,025,758	6,034,573
6,064,270	6,266,521				

©2004. Uniden America Corporation, Fort Worth, Texas
Contains additional foreign articles. Custom manufactured in China.
UBZZ01325ZB(0)